

Introduzione alla fabbricazione 3D

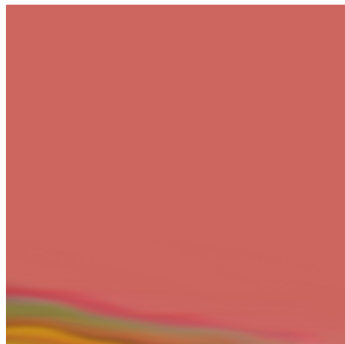

g.vozzi@centropiaggio.unipi.it

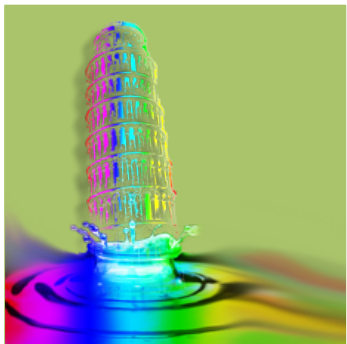
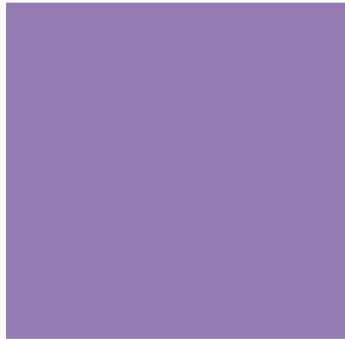

Nano-structured Microstructures

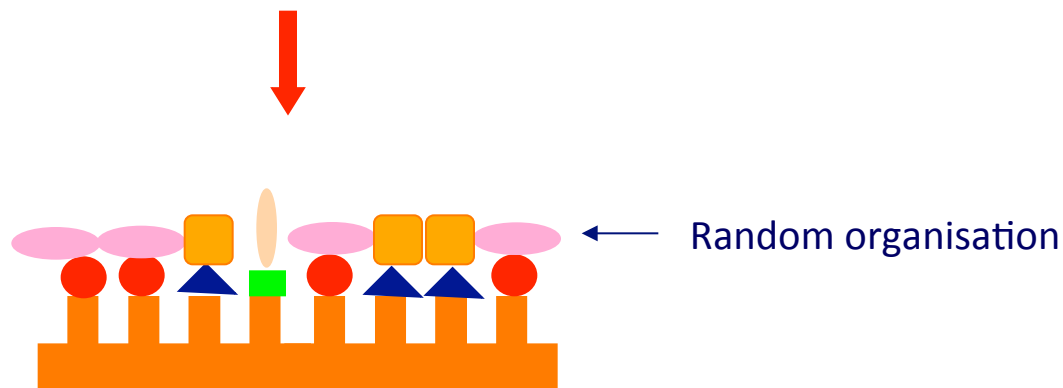
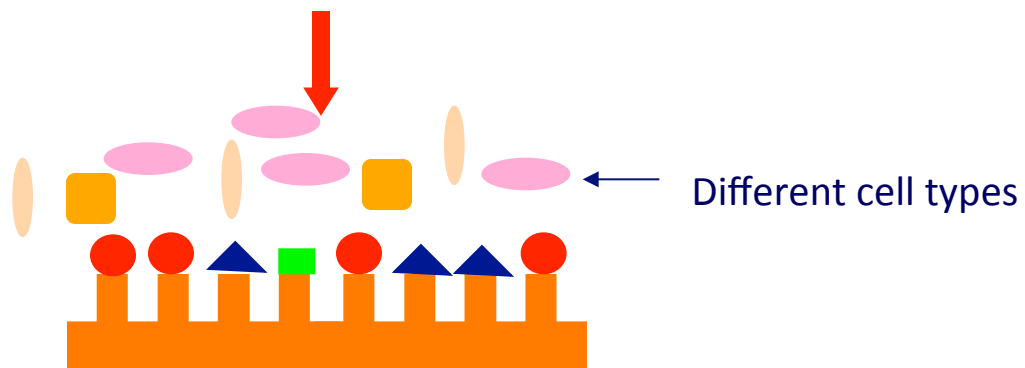
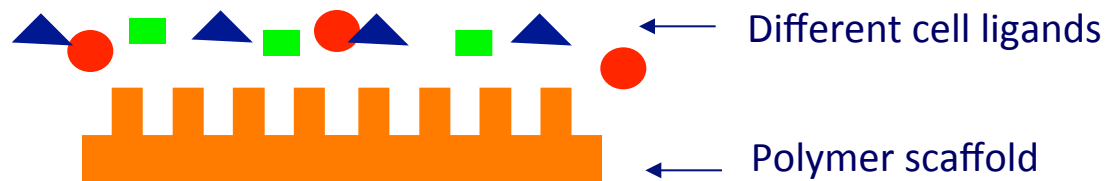



Nano-structured Microstructures

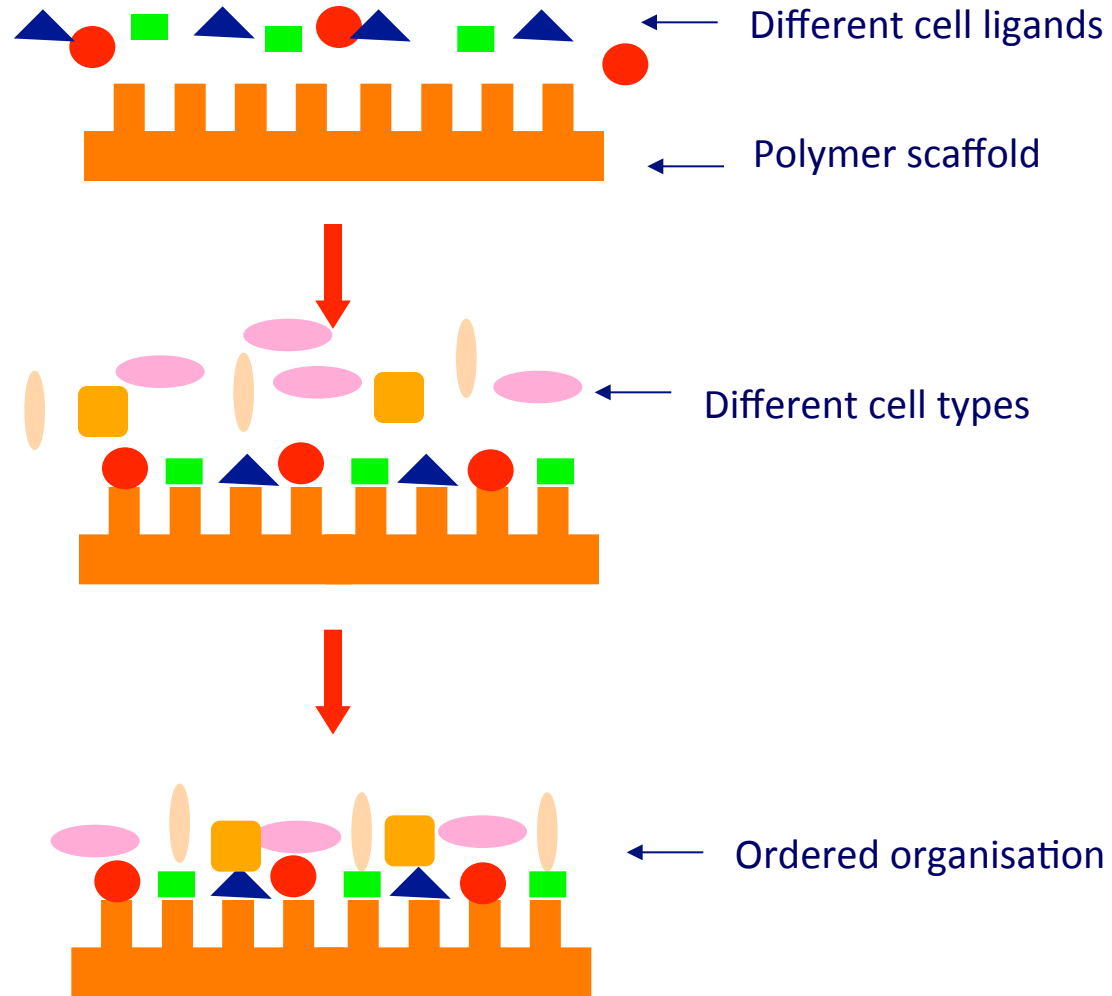

Molecular Imprinting

Molecular Imprinting is a technology that allows to realise matrix or surface, usually made of organic polymers, with specific and selective sites of recognition of a selected molecule (template) thanks to the steric and chemical complementarity

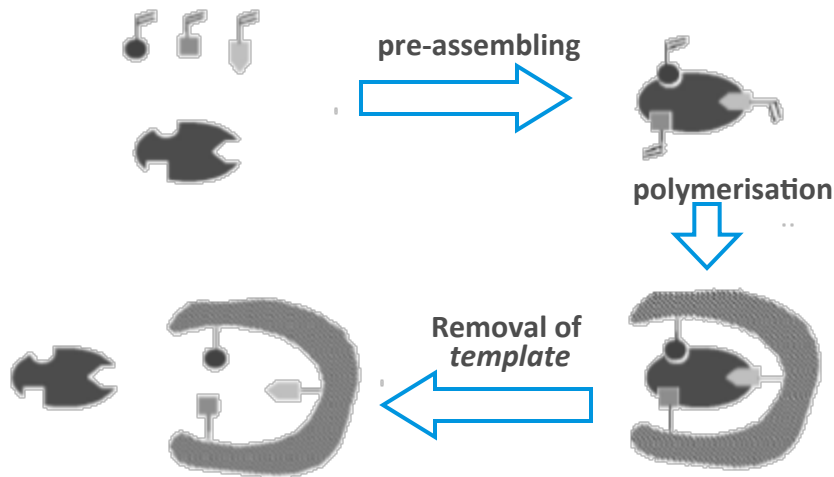

- approaches:
- **covalent interactions**
(ex. For esters and ketones; G. Wulff e K. Shea)
 - **reversible not covalent interactions**
(ex. Ionic or hydrogen bond; K. Mosbach)



SOFT-MI

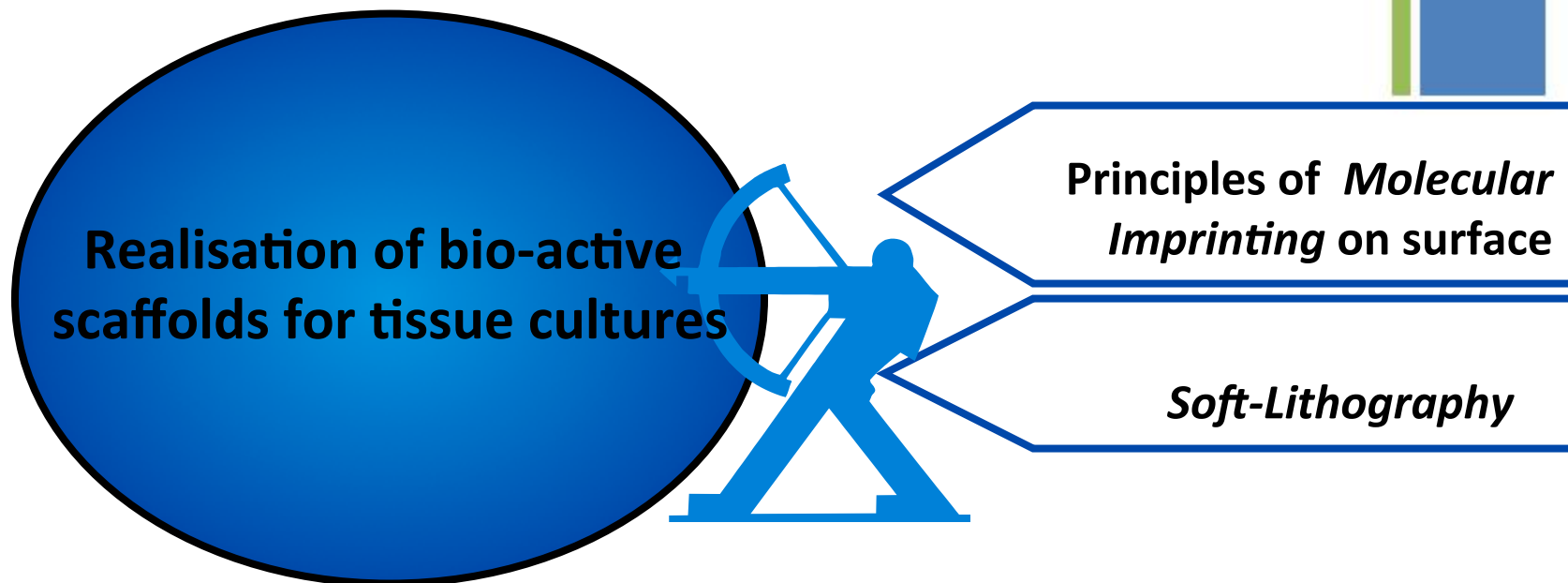

Method:

1. realisation of PDMS mold
2. modification of its superficial chemical properties
3. functionalisation of its surface
4. cell culture test

+

Realisation of mold

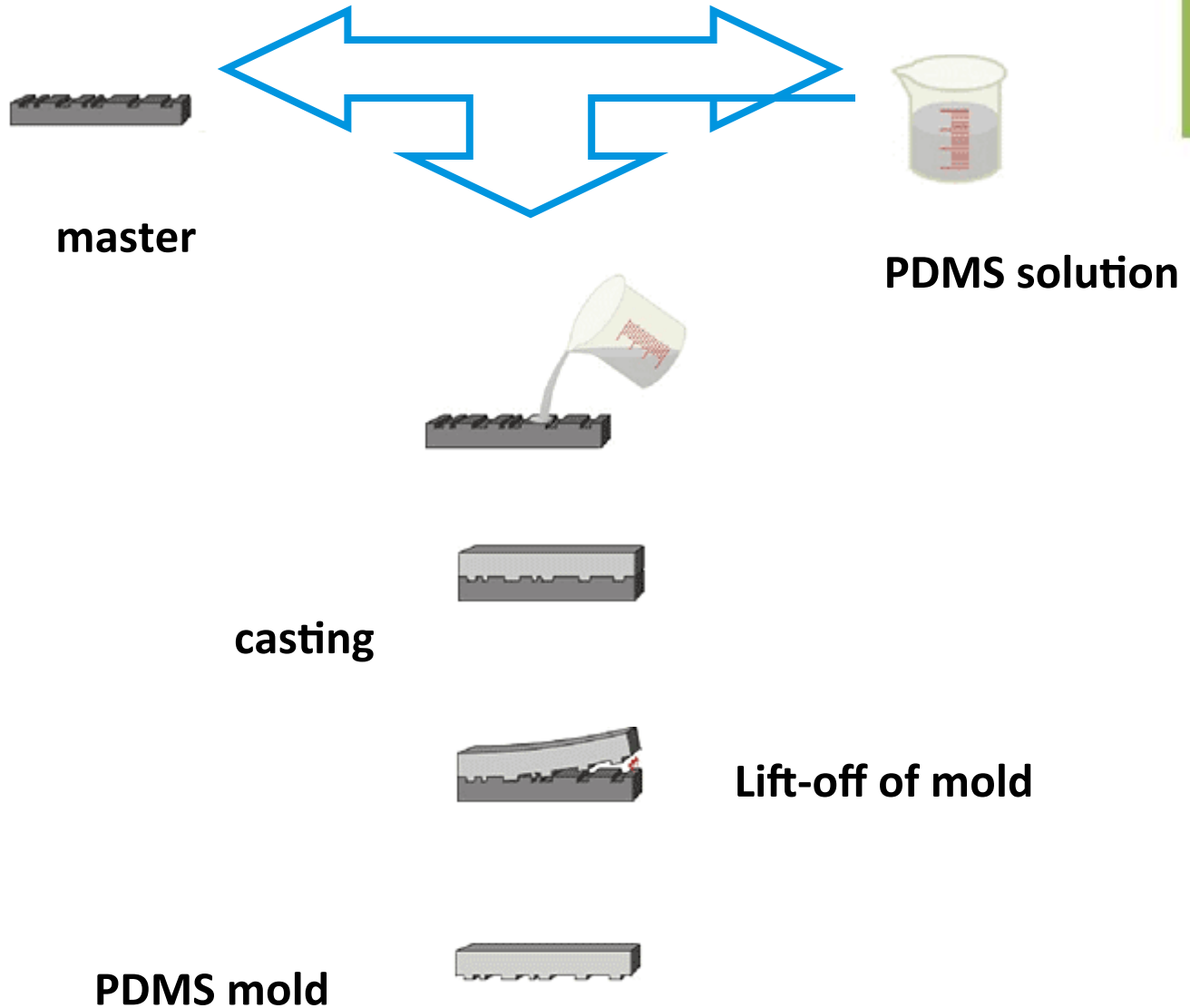



Realisation of mold

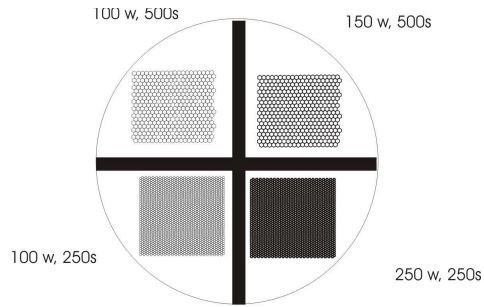

1

Mask layout

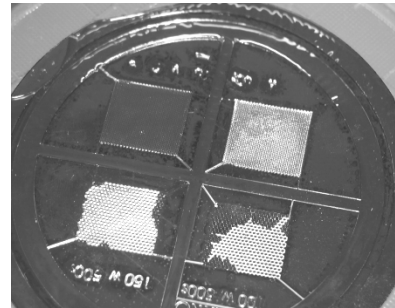

2

master

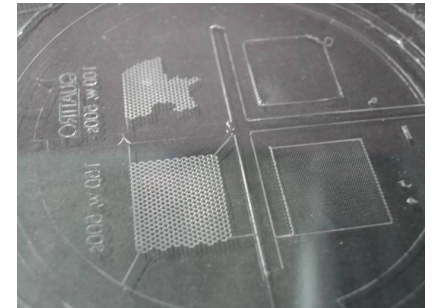

3

PDMS mold



Techniques of surface modification



Surface of PDMS is Hydrophobic

Physical and/or chemical treatment in order to increase wettability of PDMS

On the basis of state of art...

- 1. UV Exposure ($\lambda = 350 \text{ nm}$)**
- 2. Treatment with Argon plasma**

On the basis of experimental experience...

- 3. Dipping in Pirhana solution ($\text{H}_2\text{SO}_4:\text{H}_2\text{O}_2$ 30% m/m in water = 3:1 v/v)**
- 4. Dipping in H_2O_2 30% m/m in water**



Functionalisation of mold

➤ Derivatisation with poly-functional silanes in toluene solution

- 3-aminopropyl-trimethoxysilane

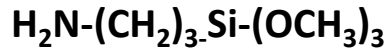

- 3-mercaptopropyl-trimethosilane

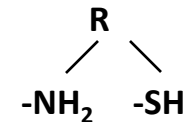
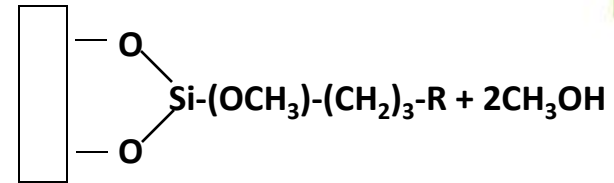
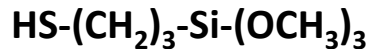

➤ Activation of reaction between Carboxylic and nucleophilic groups

solution of N-ethyl-N'-(3-dimethylamminopropyl)-carbodiimide (EDC) and N-hydroxysuccinimide (NHS) in water

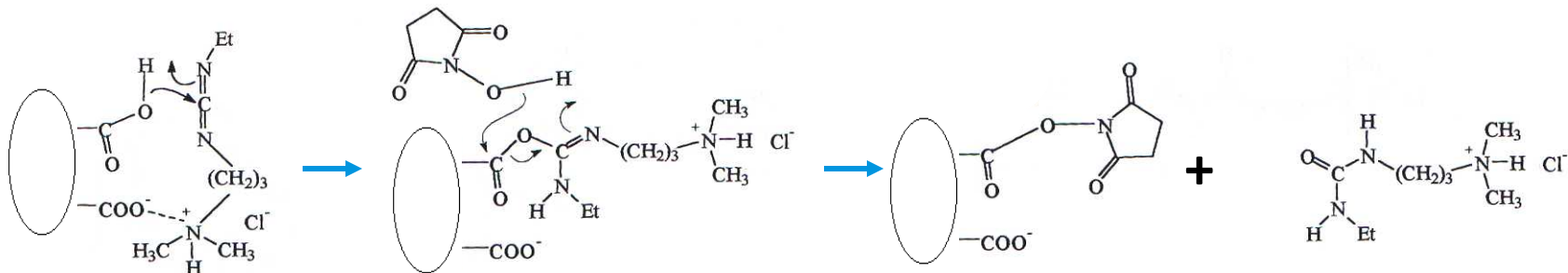



Cell adhesion test



protocol:

- Fabrication of PDMS mold functionalised with a protein (Gelatin)
- Realisation of polymer *scaffold with micromolding method using 20% polymethylmethacrylate (PMMA) solution in CHCl_3*
- Rebonding of protein with imprinted scaffold
- Cell seeding with Murine Fibroblasts (NIH-3T3)
- Cell Fixing and staining at different time intervals (6/24/48 h)

Example of PMMA scaffold

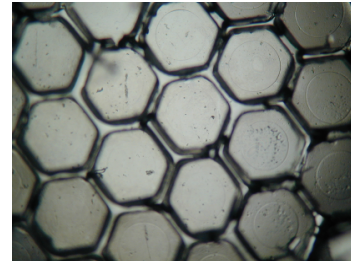



Cell adhesion and Proliferation

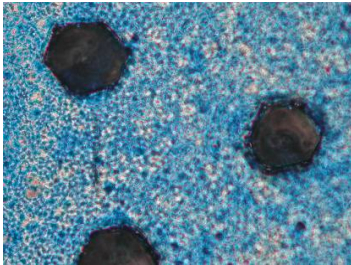

**UV exposure
amino-silane
48 h**

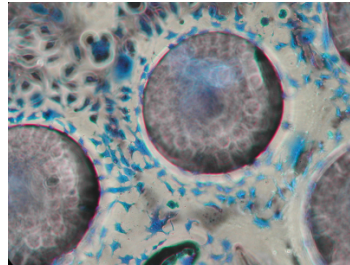

**Pirhana solution
mercapto-silane
48 h**

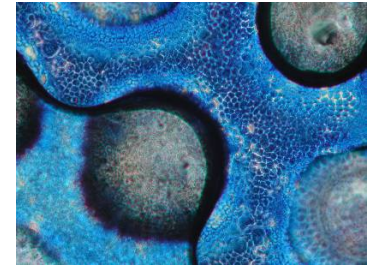

**Argon Plasma
mercapto-silane
48 h**

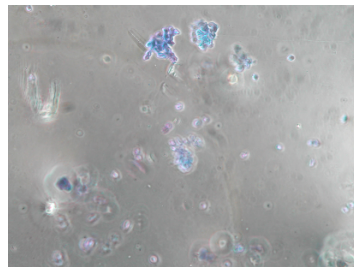

**Control (Film of PMMA)
48 h**

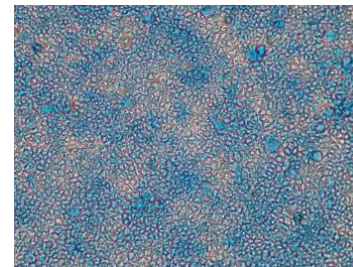

**Control (Gelatin)
48 h**



Synthesis of results

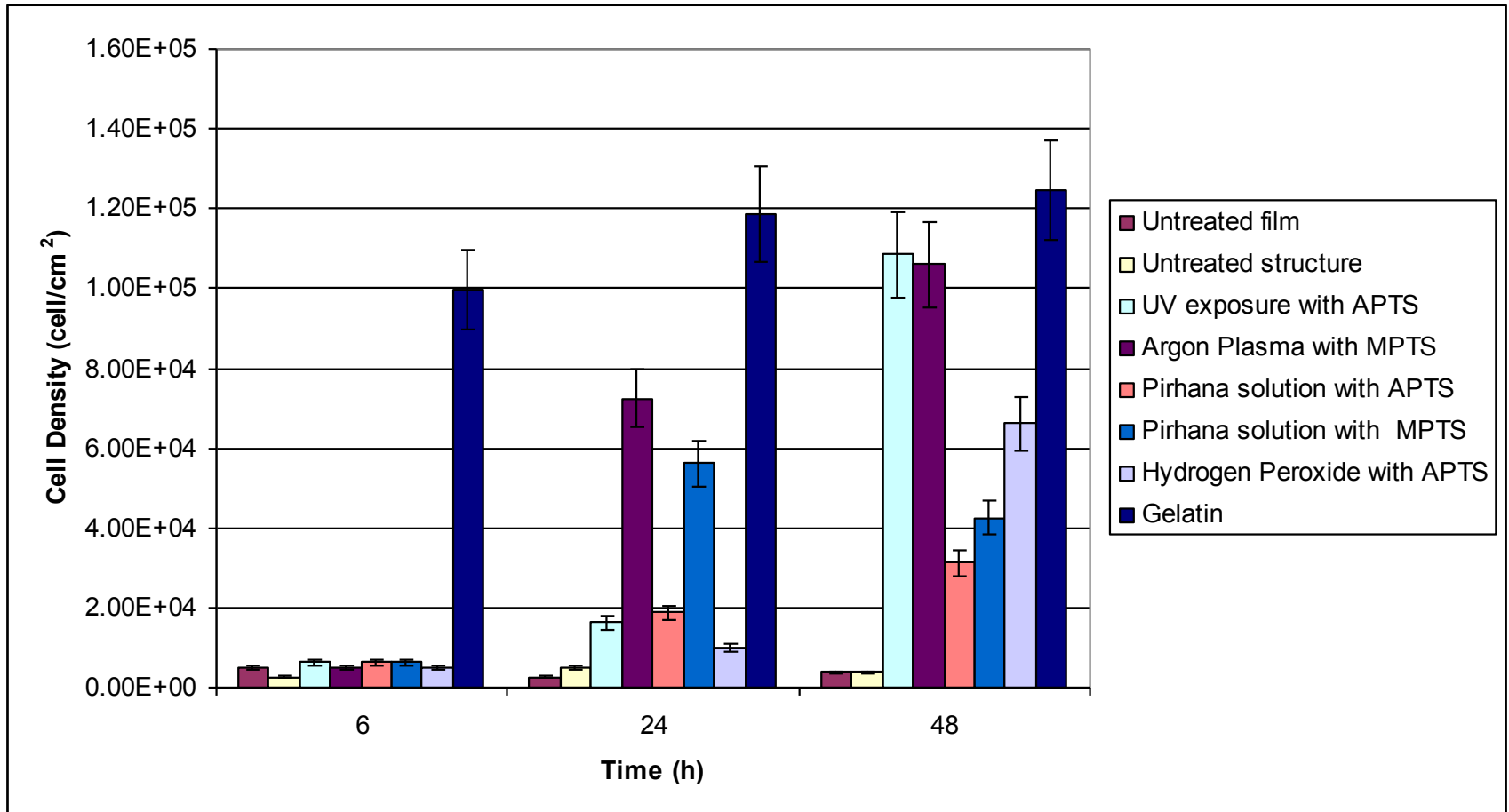



Imprinting cells



PDMS mold



Functionalisation of PDMS mold



Cell Seeding and fixing

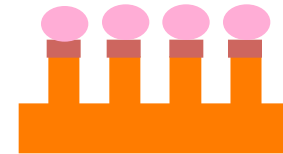

Polymer Casting

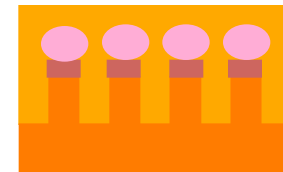

Realisation of Polymer Scaffold



Cell Seeding on functionalised polymer scaffold



+

Imprinting cells

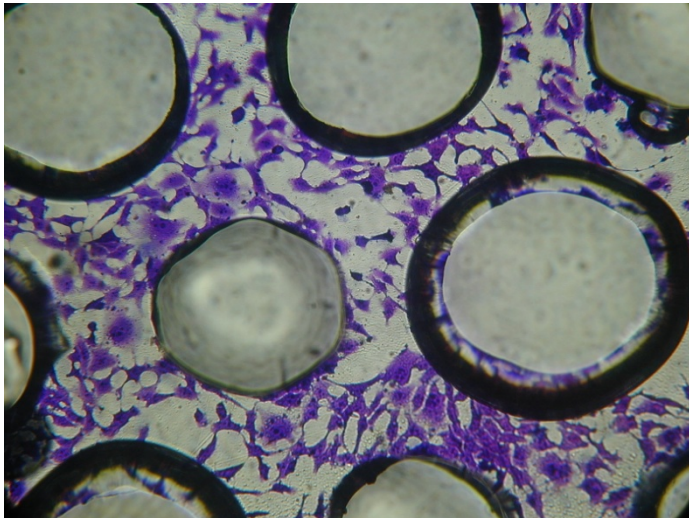
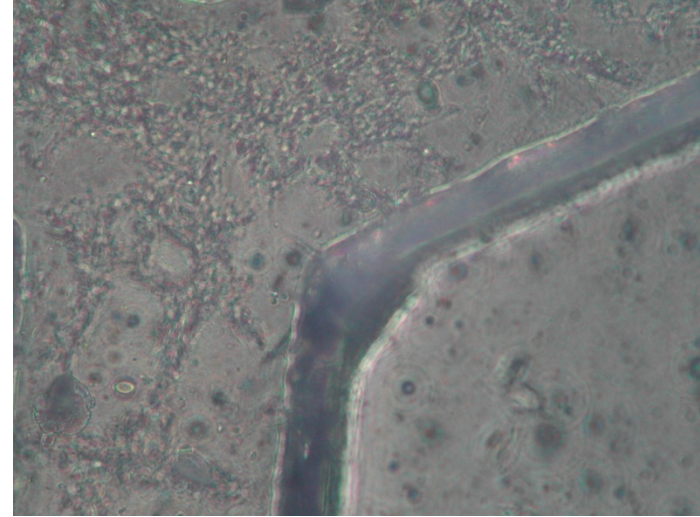
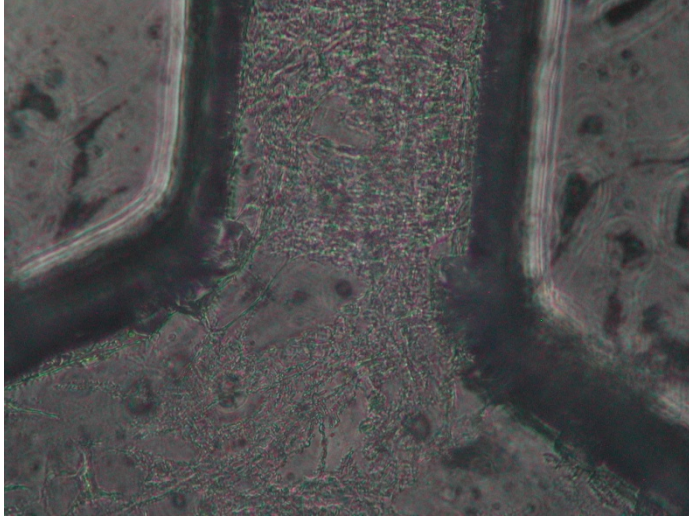

24h

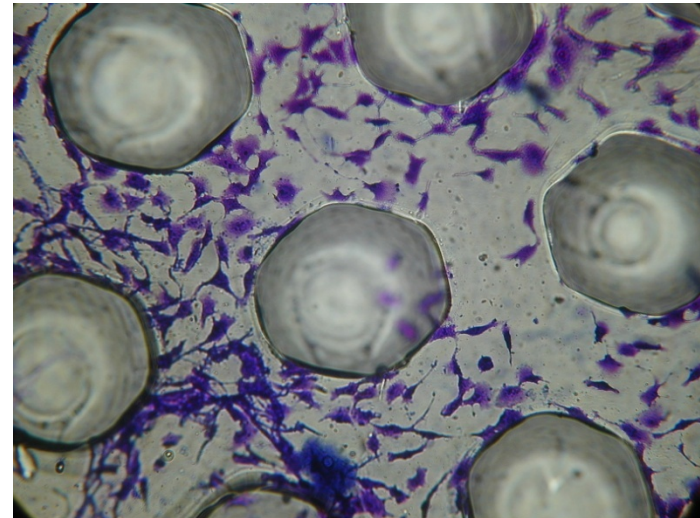

+

Imprinting cells

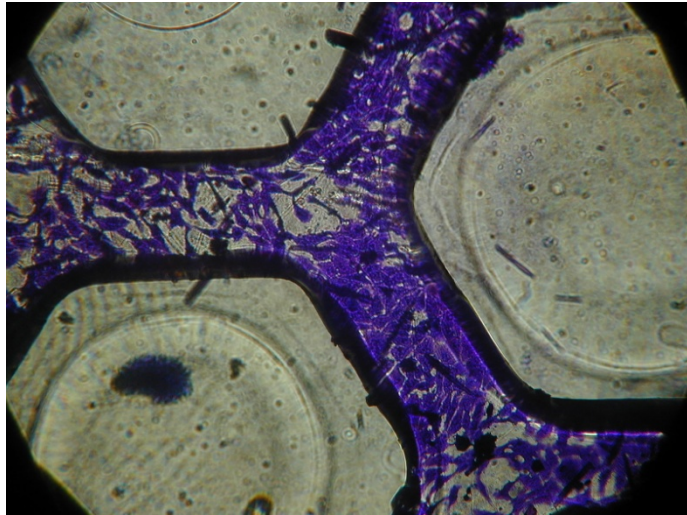

48h

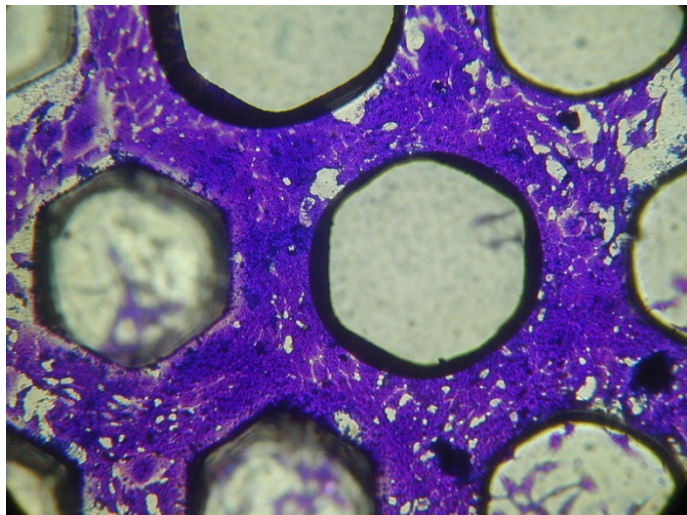
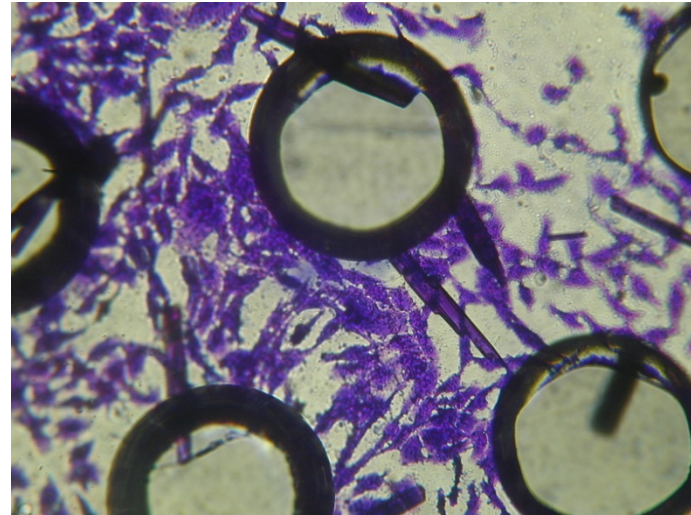

72h

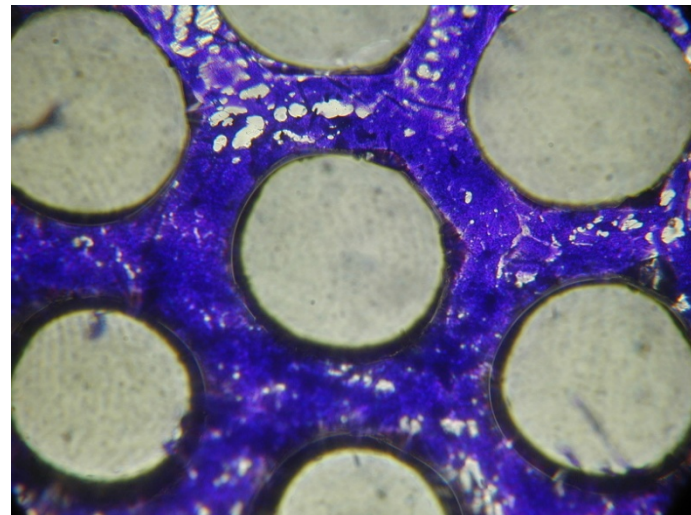

+

Designer Scaffold

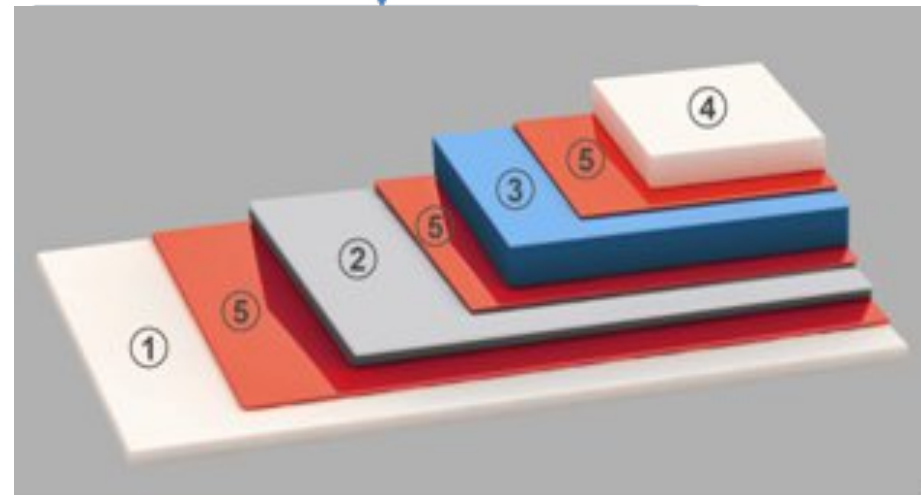

+ Designer Scaffold

Additive = rapid prototyping

Additive

Subtractive

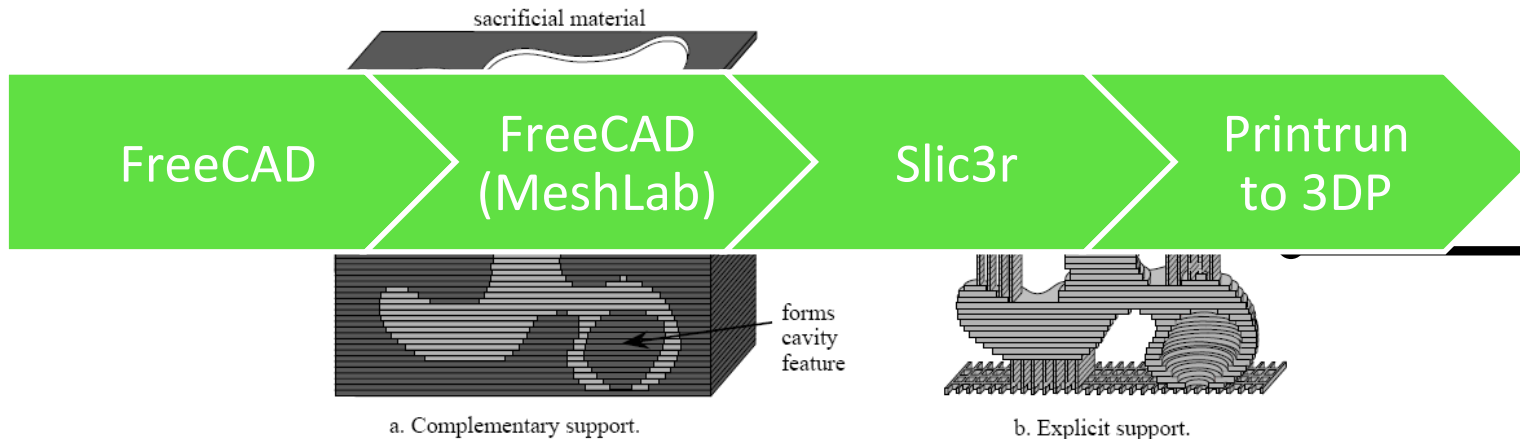
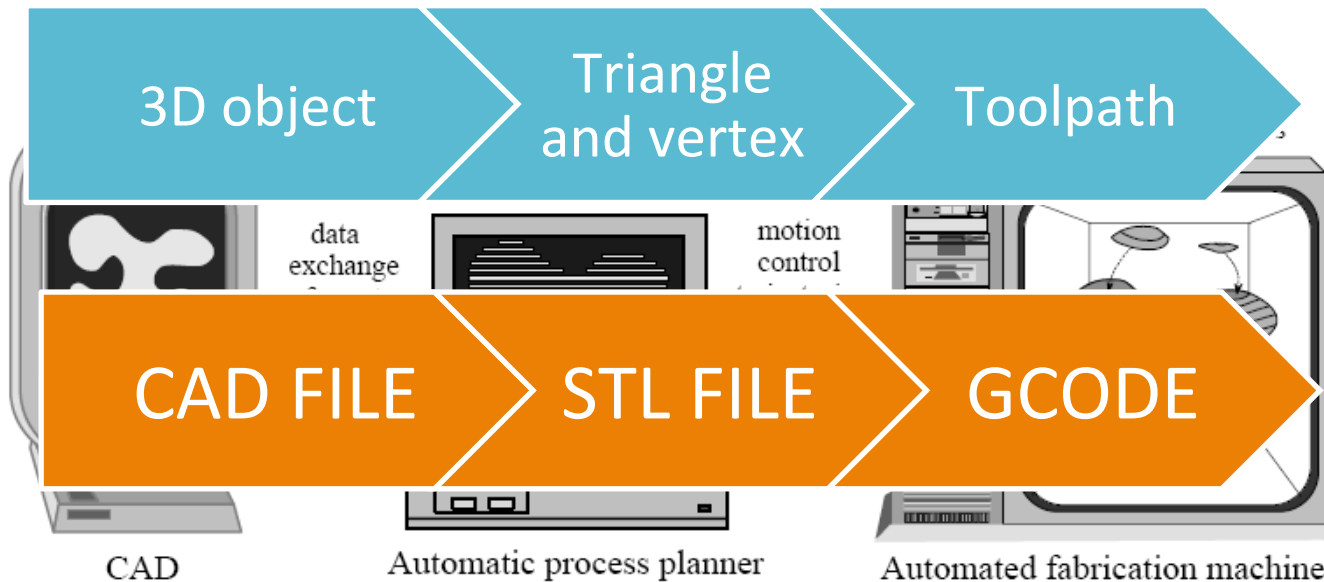



Rapid Prototyping (RP) Techniques



Three main groups:

- laser systems
- nozzle based systems
- direct writing systems

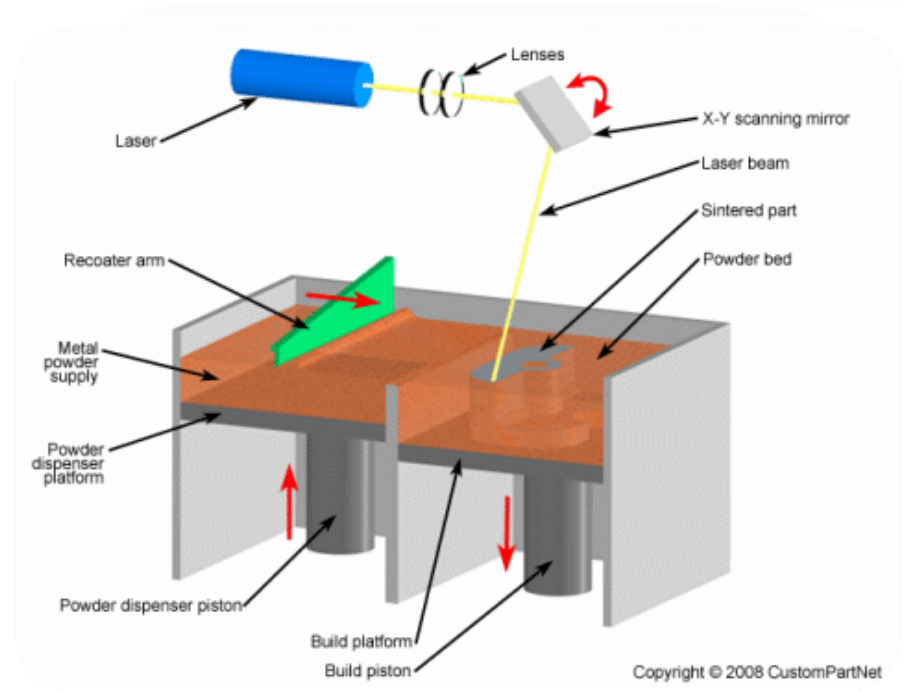

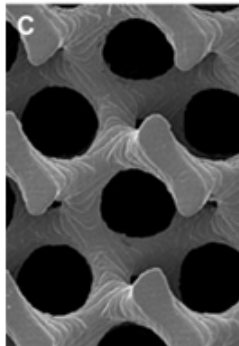
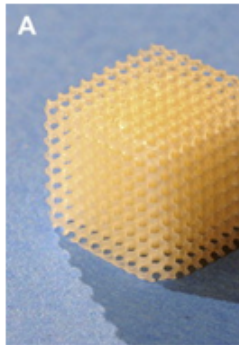
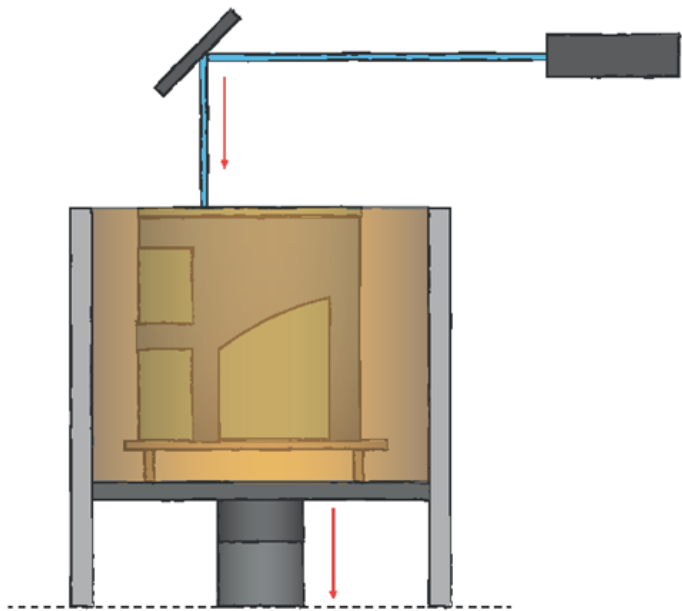



Risultati

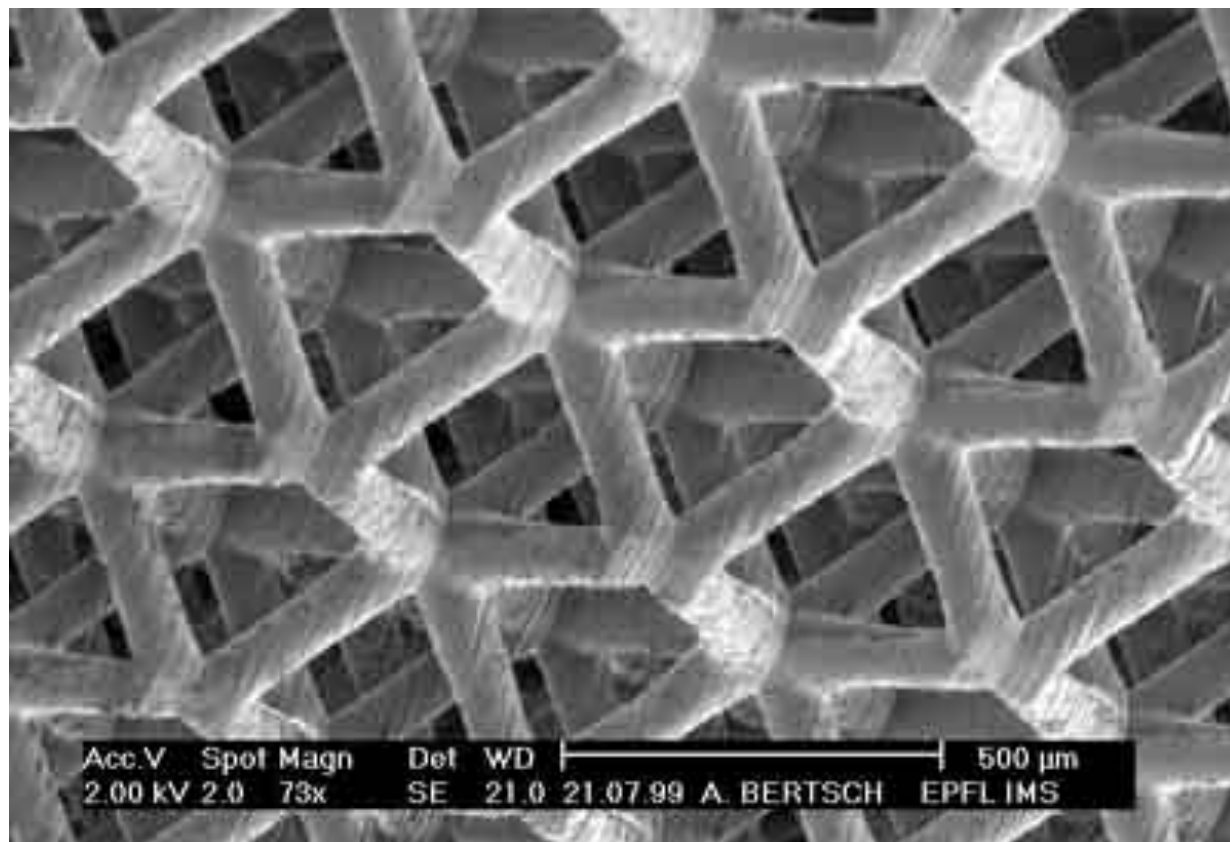

Fused Deposition Modeling

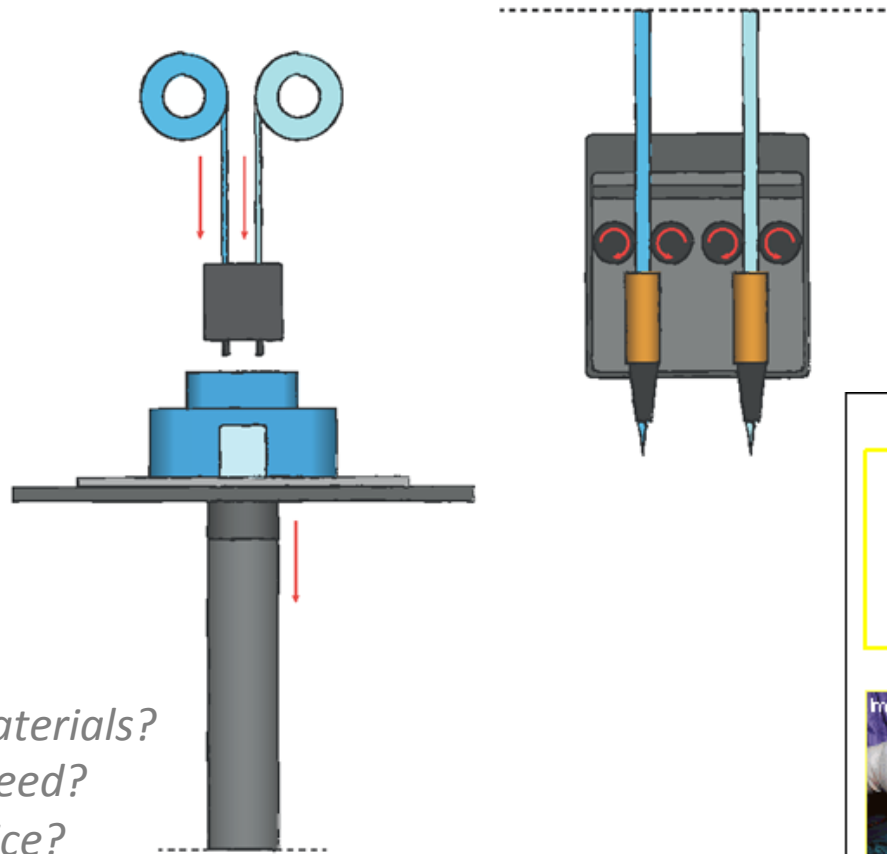
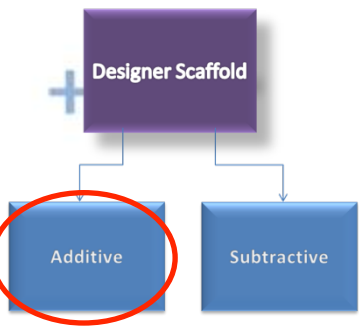

Materials?
Speed?
Price?
Fidelity?

Hutmacher & coworkers

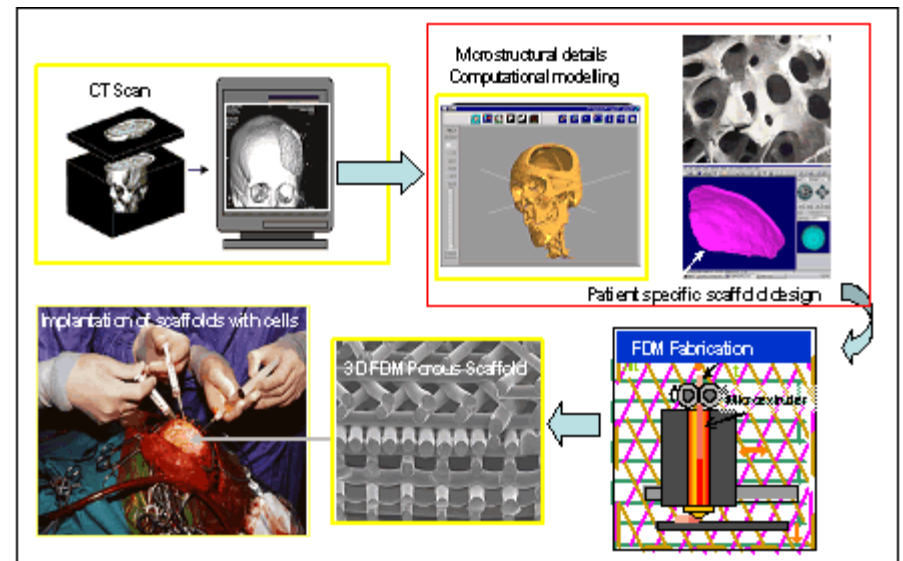
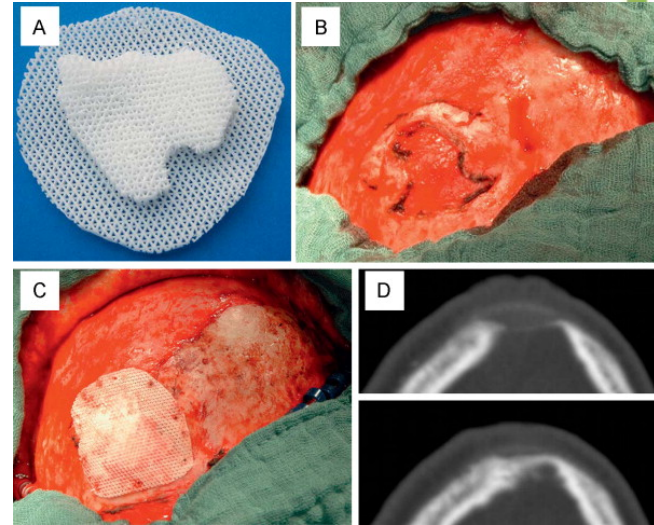
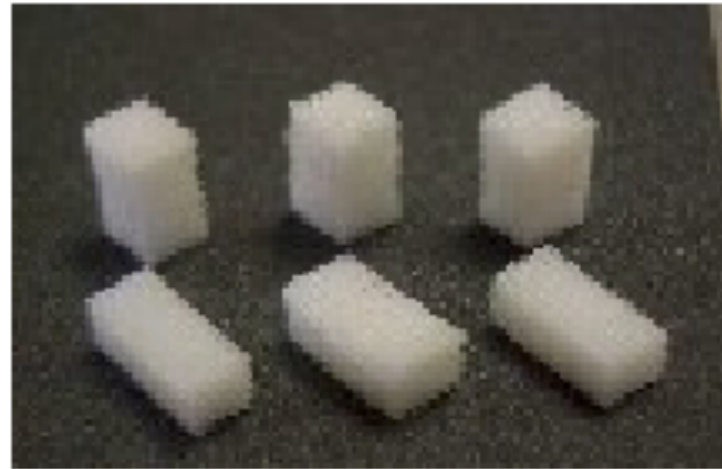
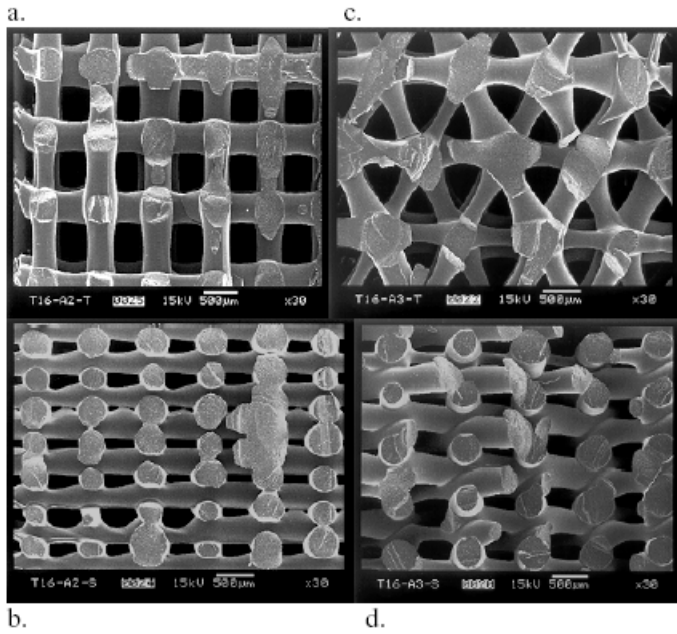

Figure 1: Platform technology for patient specific scaffolds TE.



Risultati



3D Printing™

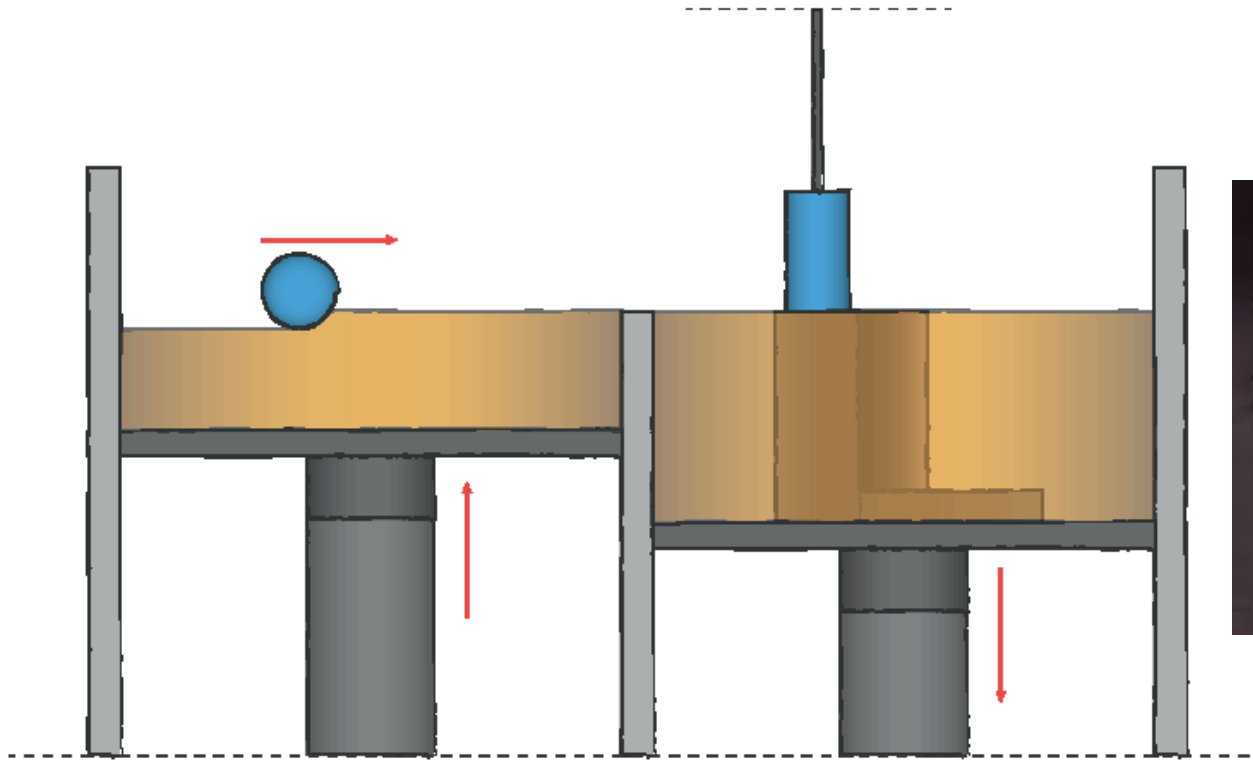
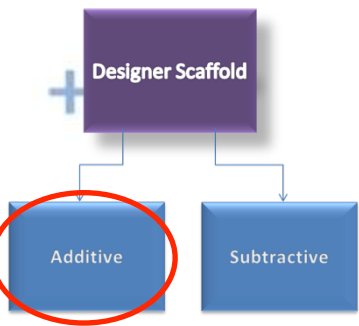

Materials?
Speed?
Price?
Fidelity?

+

Risultati

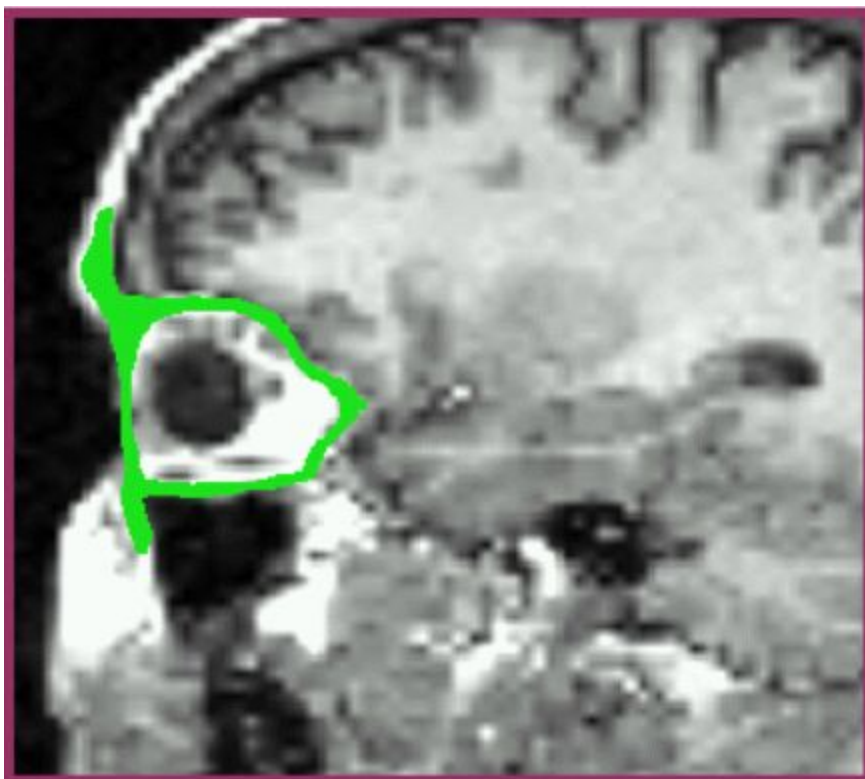

Membrane Lamination

+ Designer Scaffold

Additive

Subtractive

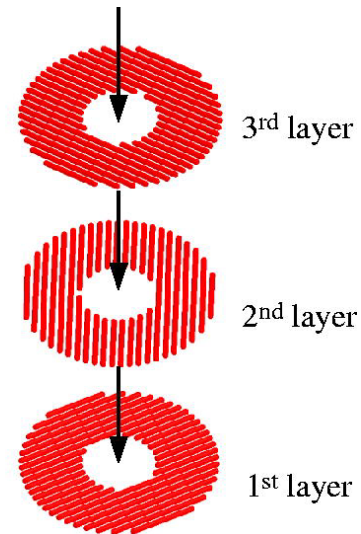
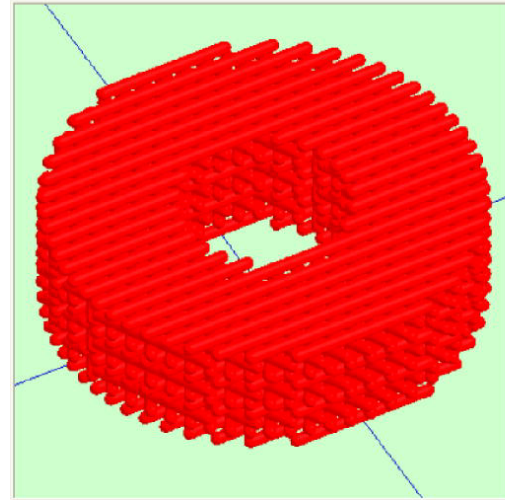
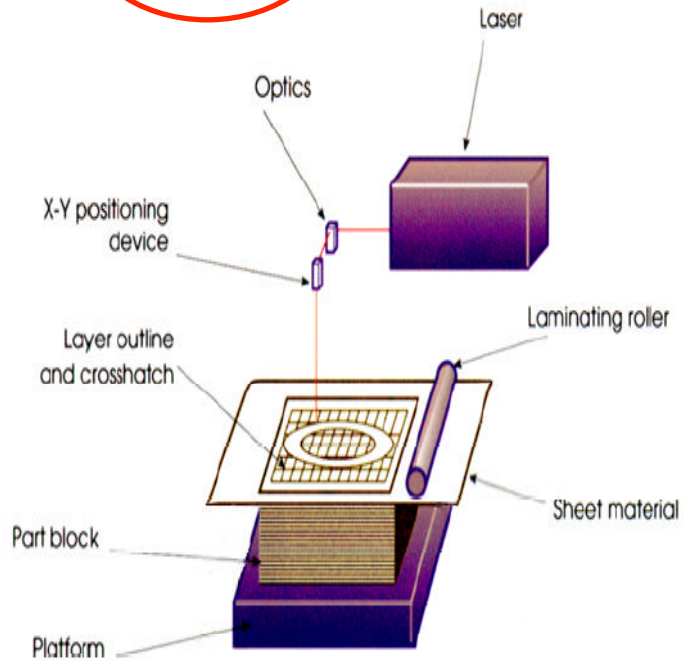

Laser as a cutter

Materials?
Speed?
Price?
Fidelity?



Risultati

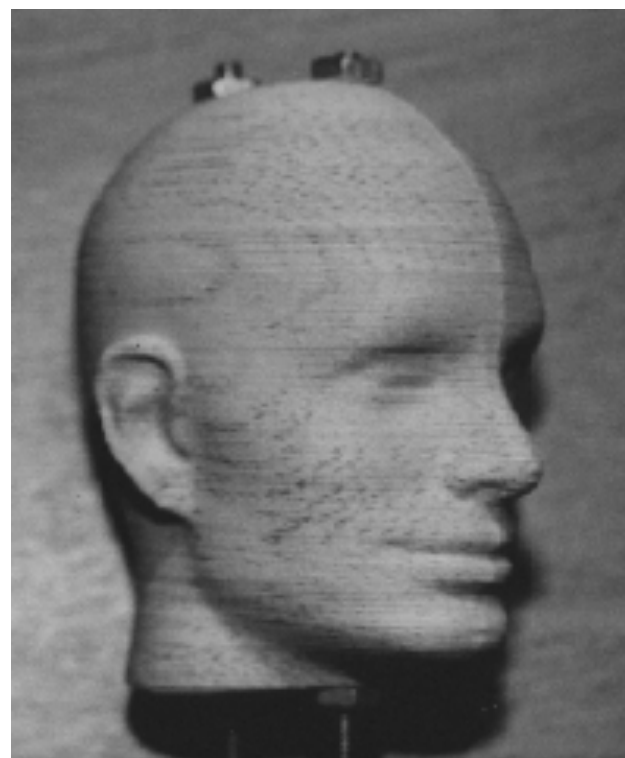
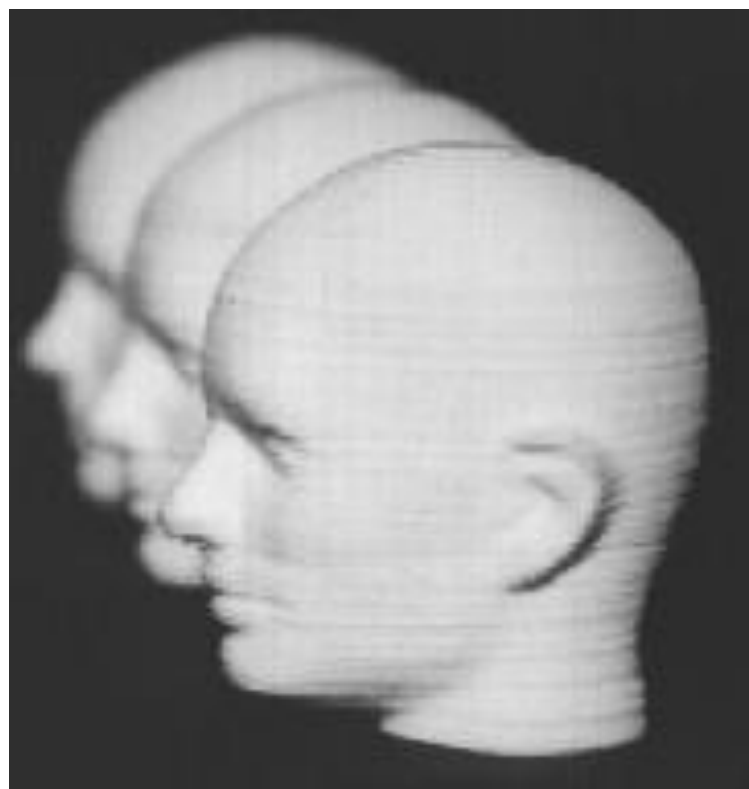



Laser Sintering

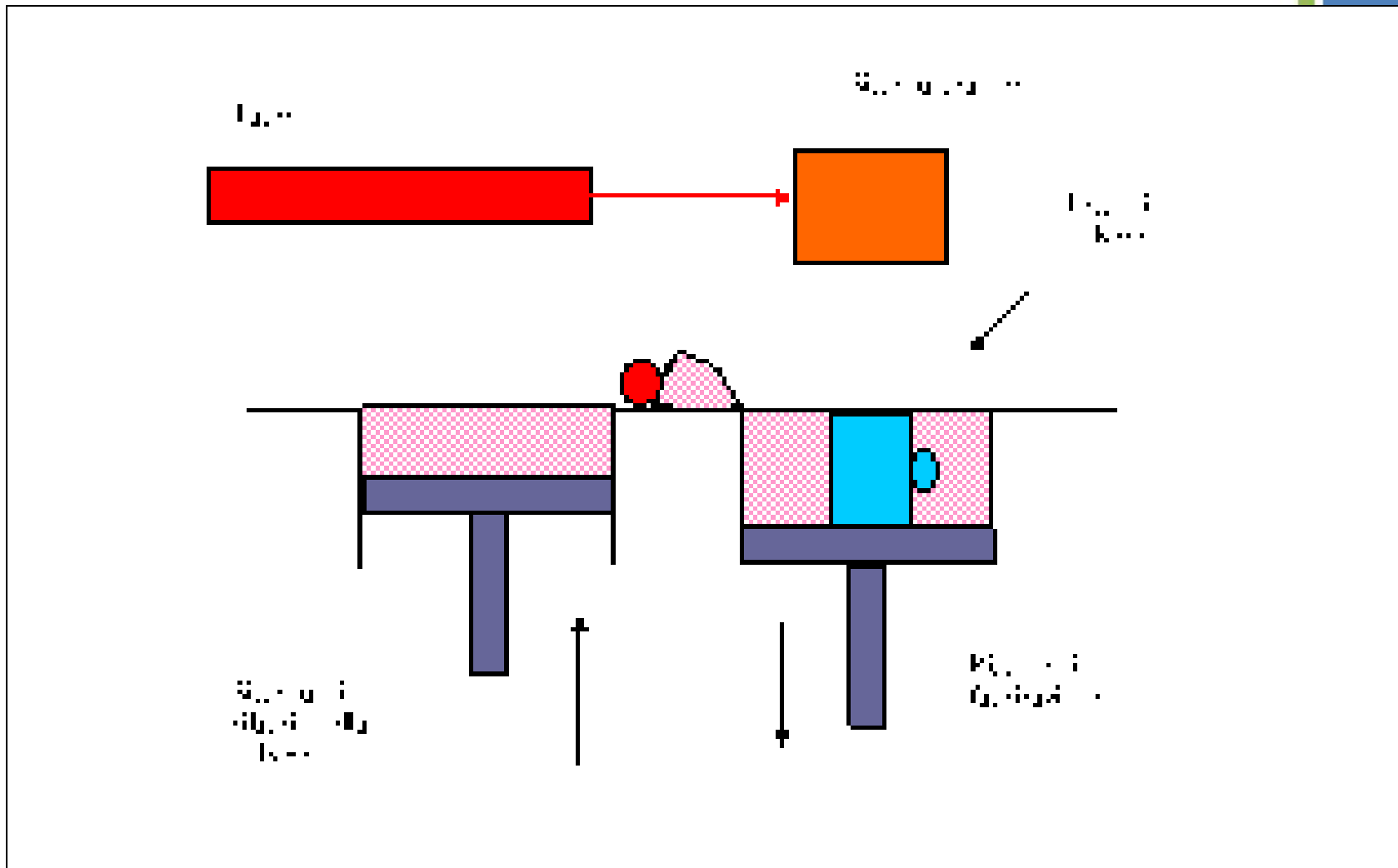

+

Risultati





Bioplotter

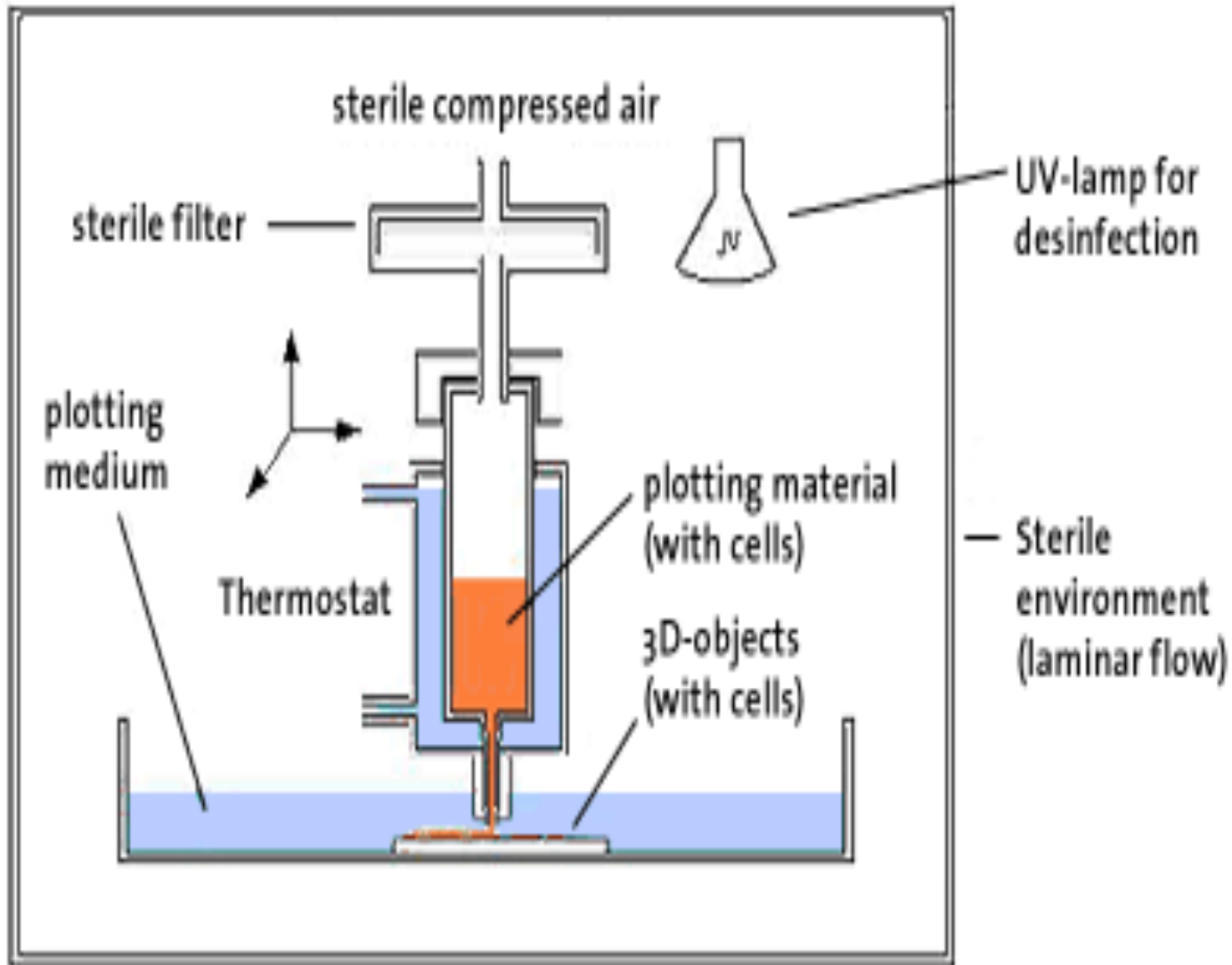

+

Risultati

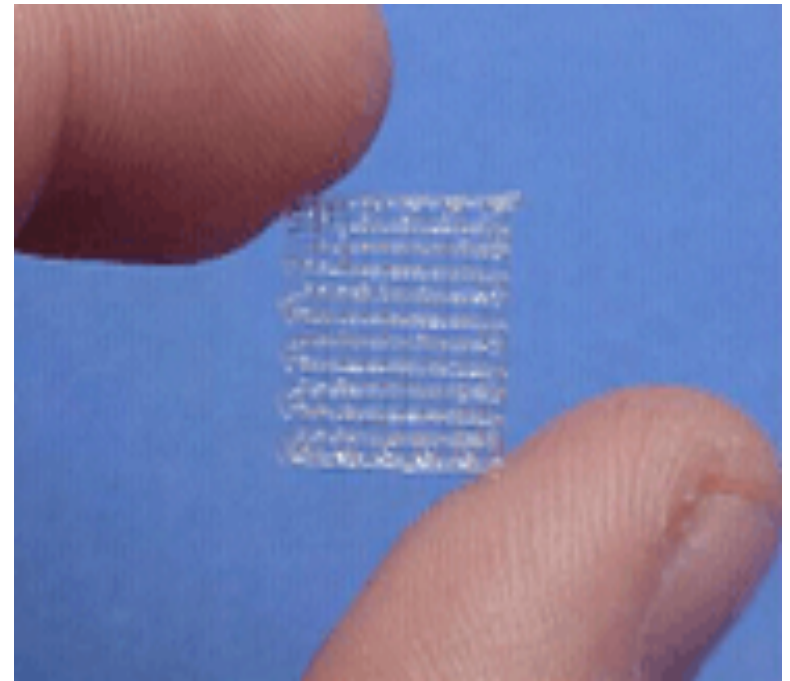
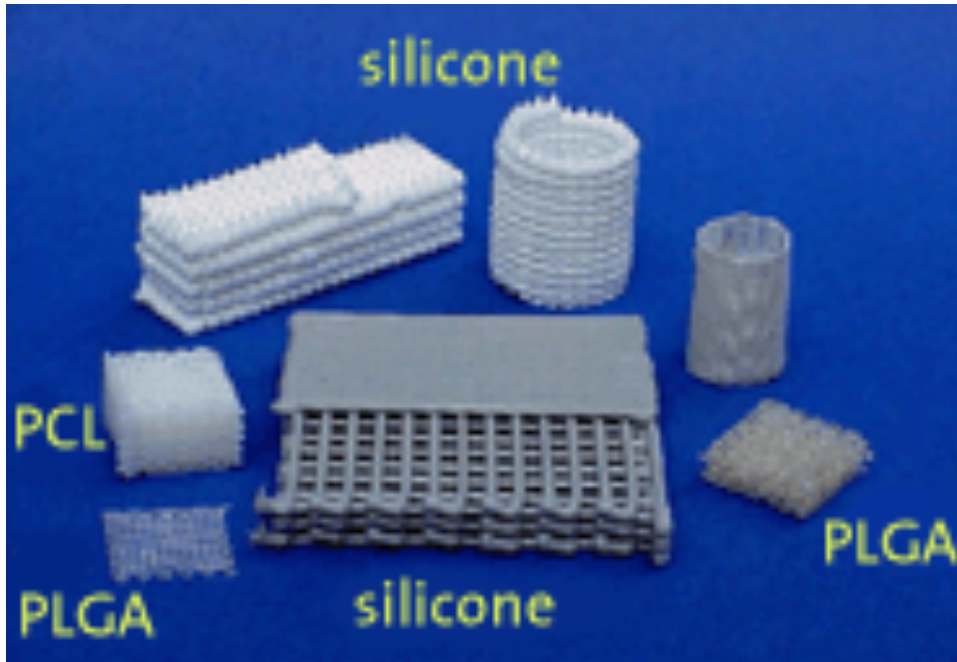

Pressure Assisted Microsyringe (PAM)

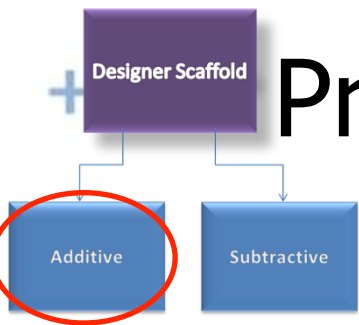

Regulated air flow

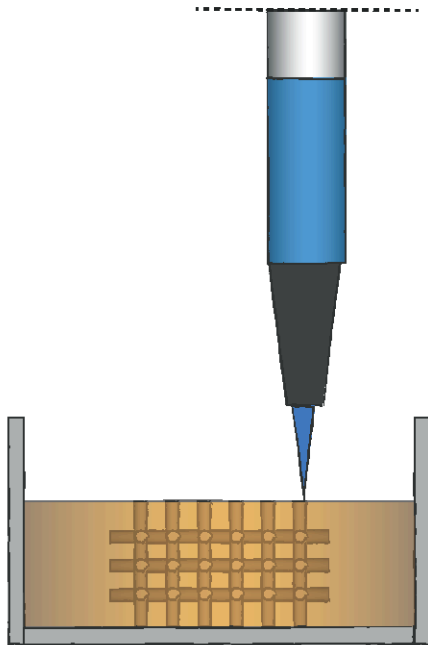

PAM system

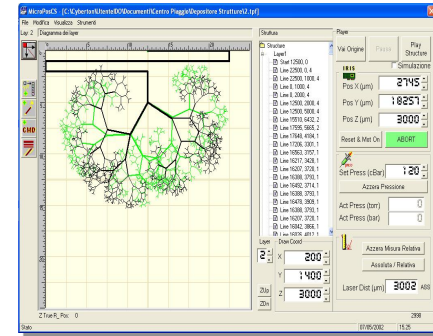

Software

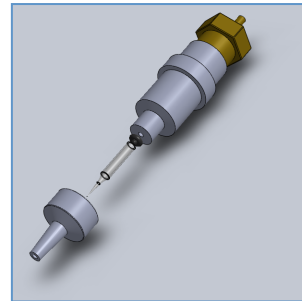

Syringe design

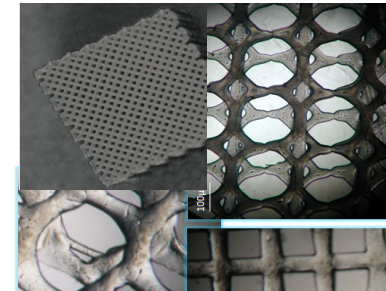

Software

Materials?
Speed?
Price?
Fidelity?

Vozzi, Previti, De Rossi, *Tissue Engineering*, 8, 34, 2002. Vozzi, Flaim, Ahluwalia, Bhatia, *Biomaterials*, 24, 2533, 2003

Scaffolds with PAM

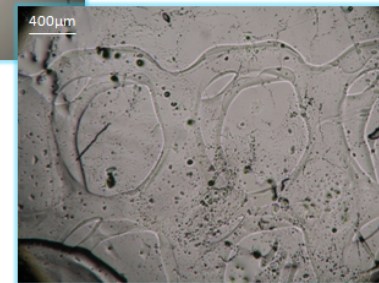
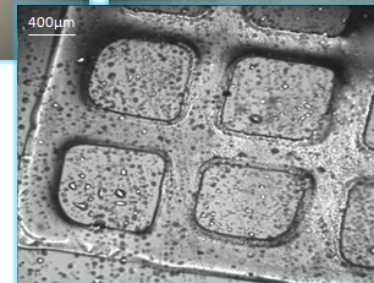
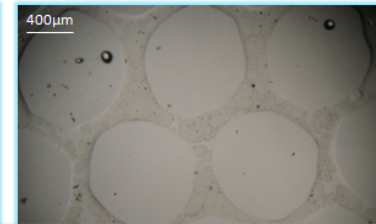
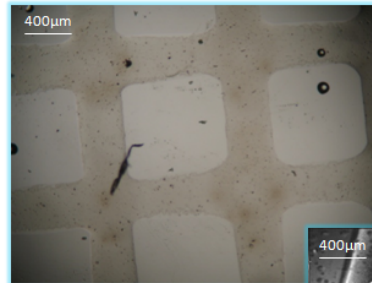
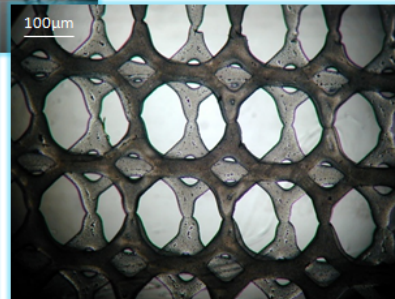
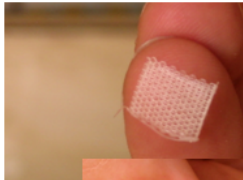
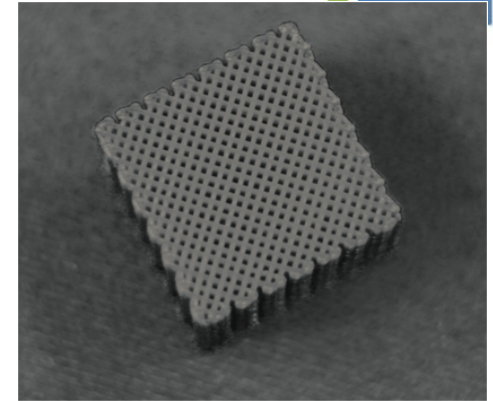
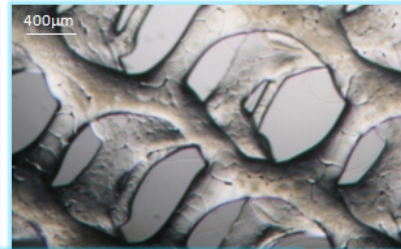
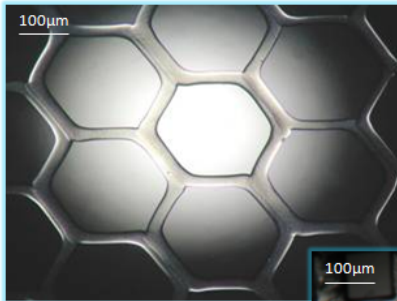
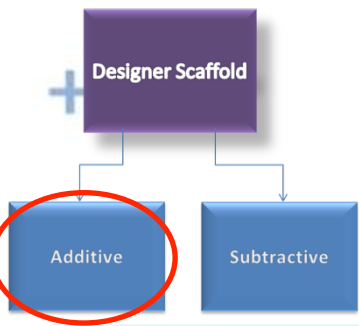

Materials?
Speed?
Price?
Fidelity?

Vozzi et al, *JBMRA*, 71A, 326, 2004.
Mariani et al., *Tissue Eng.* 12, 547, 2006.
Bianchi et. Al. *JBMR* 81, 462, 2007.

Piston Assisted Microsyringe (PAM2)

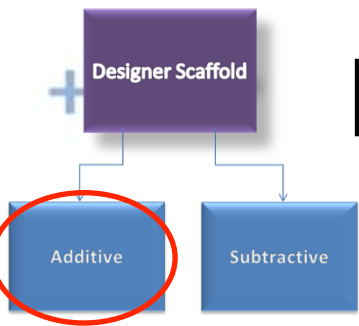

Plunger driven

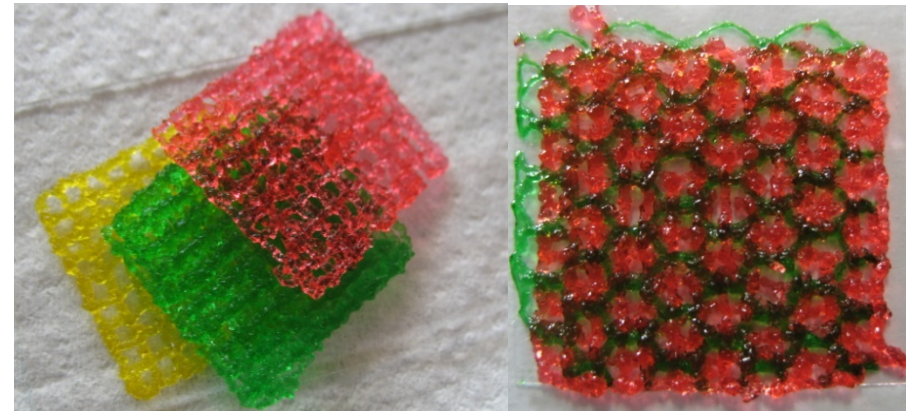
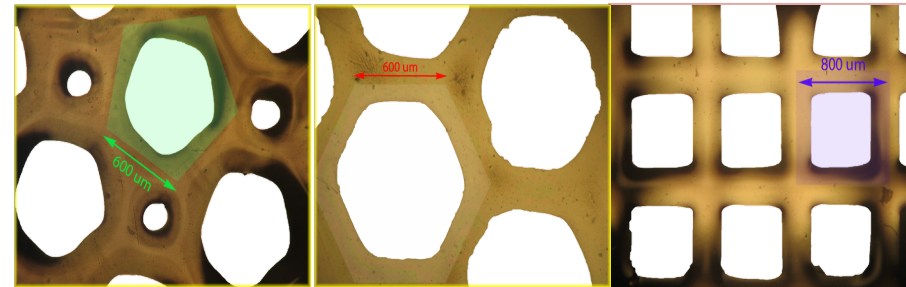
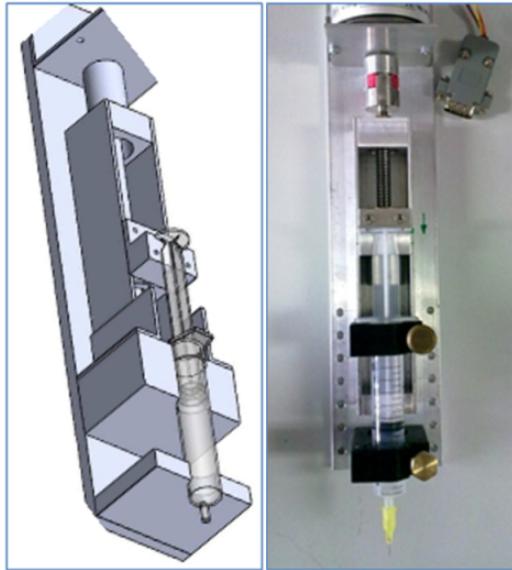

Materials?
Speed?
Price?
Fidelity?

Vozzi, G., Tirella, A., Ahluwalia, A., *Computer-Aided Tissue Engineering*, Springer (2010); Tirella, De Maria, Vozzi, Ahluwalia *Rapid Prot. J* (2012); Tirella, Orsini, Vozzi, Ahluwalia *Biofabrication* (2009),

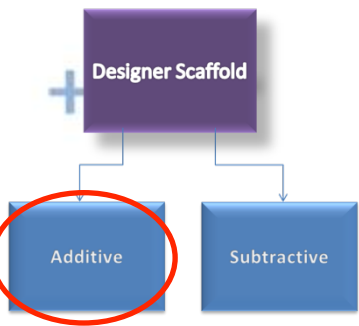

The PAM2 system

Robotic 3 axis micropositioner.

- ✓ PAM
- ✓ PAM2
- ✓ Diode laser
- ✓ Temperature control
- ✓ PAM² software

- 4 Position controlled brushless motors (resolution of 10 μm ± 1 μm)
- Working space 100×100×80 mm
- Working velocity 1-15 mm ·s⁻¹
- Design of z-stage to locate several modules

Materials?

Speed?

Price?

Fidelity?

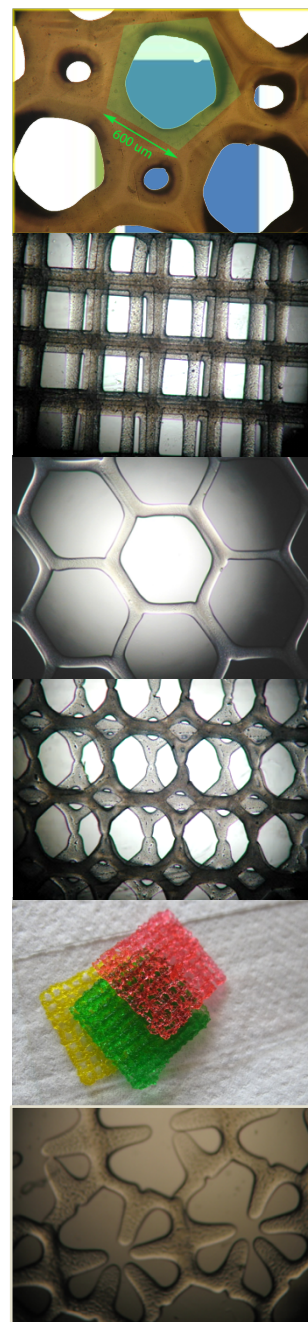
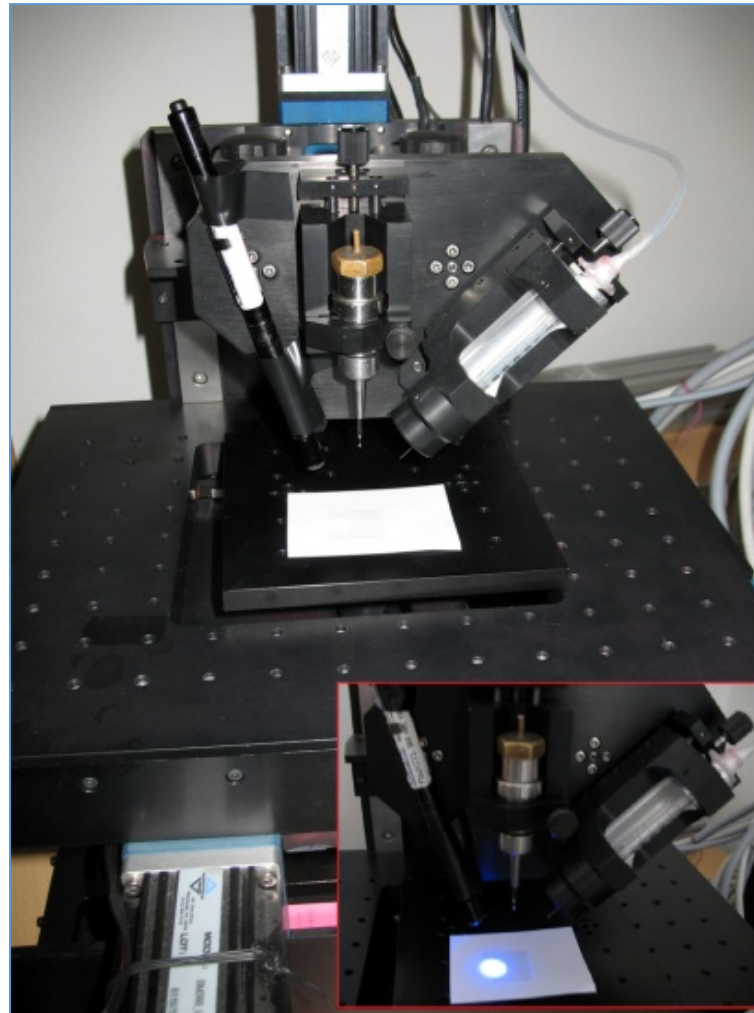

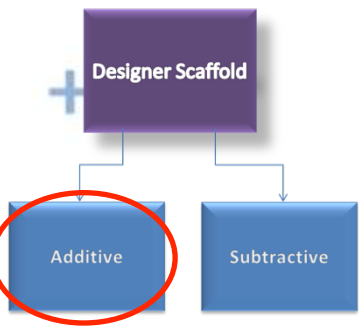

Inkjet Printing



Inkjet technology is a **contact free dot matrix printing** procedure. Ink is issued from a small aperture directly onto a specific position on a substrate

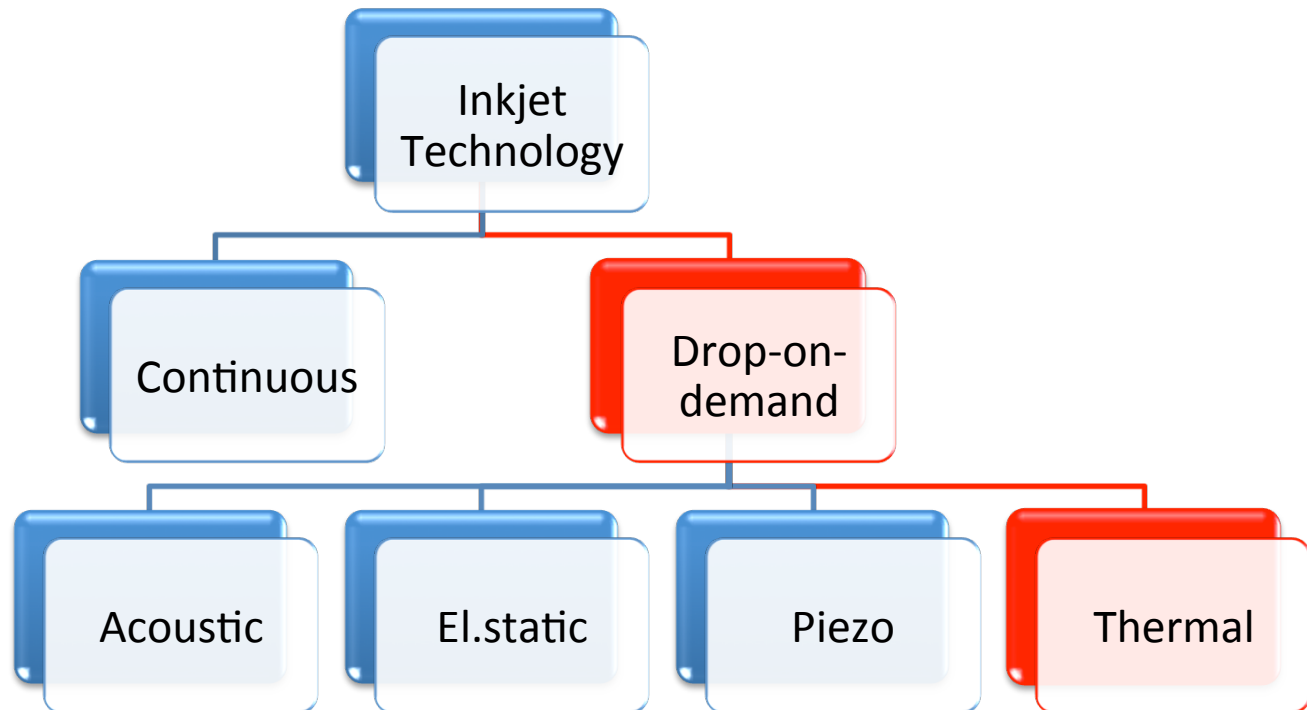

Materials?
Speed?
Price?
Fidelity?

+ Designer Scaffold

Penelope Ink-Jet printer

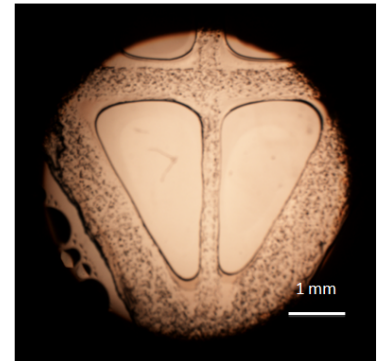
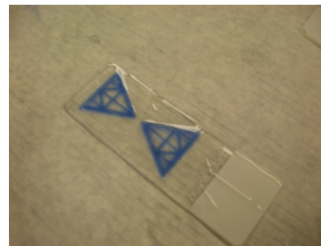
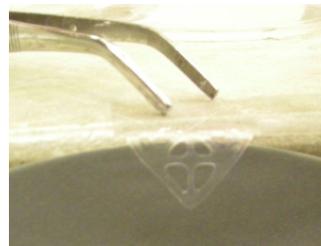
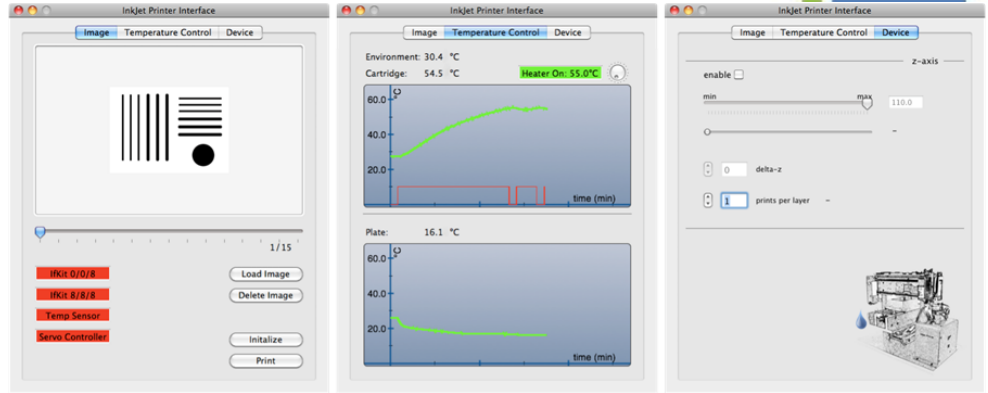
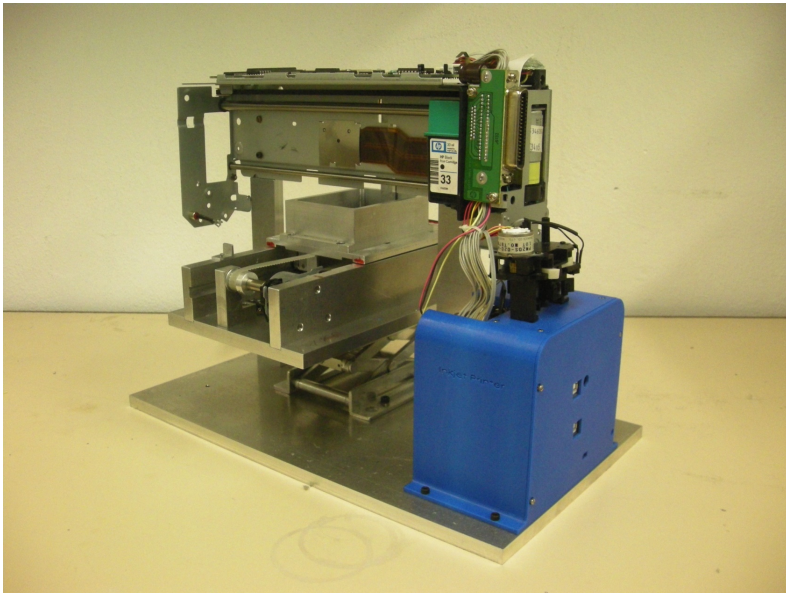
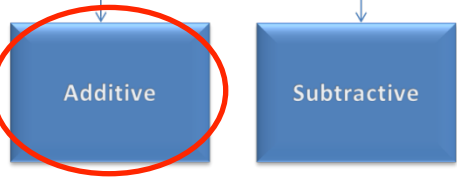

Materials?
Speed?
Price?
Fidelity?

+ Open source FDM machine: RepRap Project



- RepRap is first general-purpose self-replicating manufacturing machine.
- An open source project with several forks

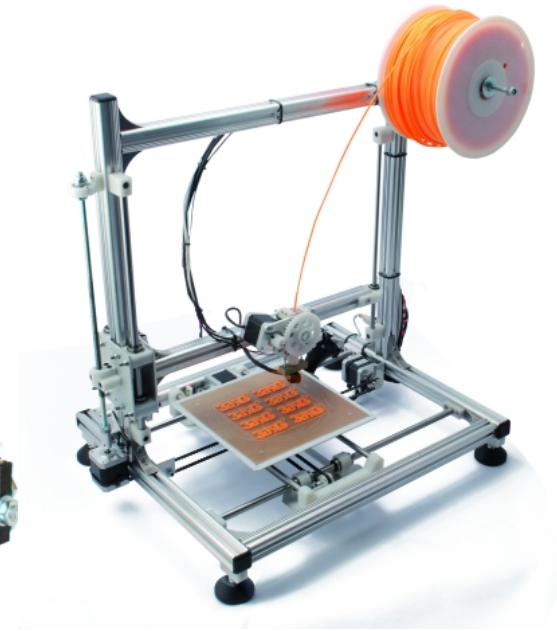
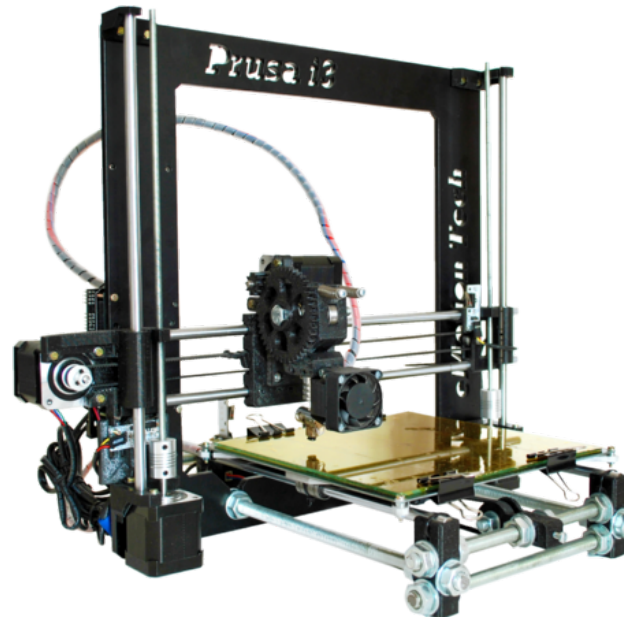
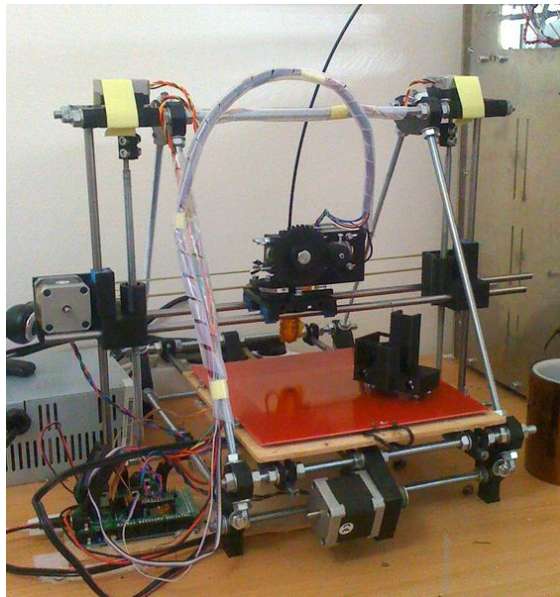



iRP using Open Source FDM



Extruded material	Casted Materials	Extraction method	Resolution (μm)
Carbohydrate-glass (with a subsequent coating with PDLGA)	Agarose, Alginate, PEG, Fibrin, Matrigel	Water dissolution	500

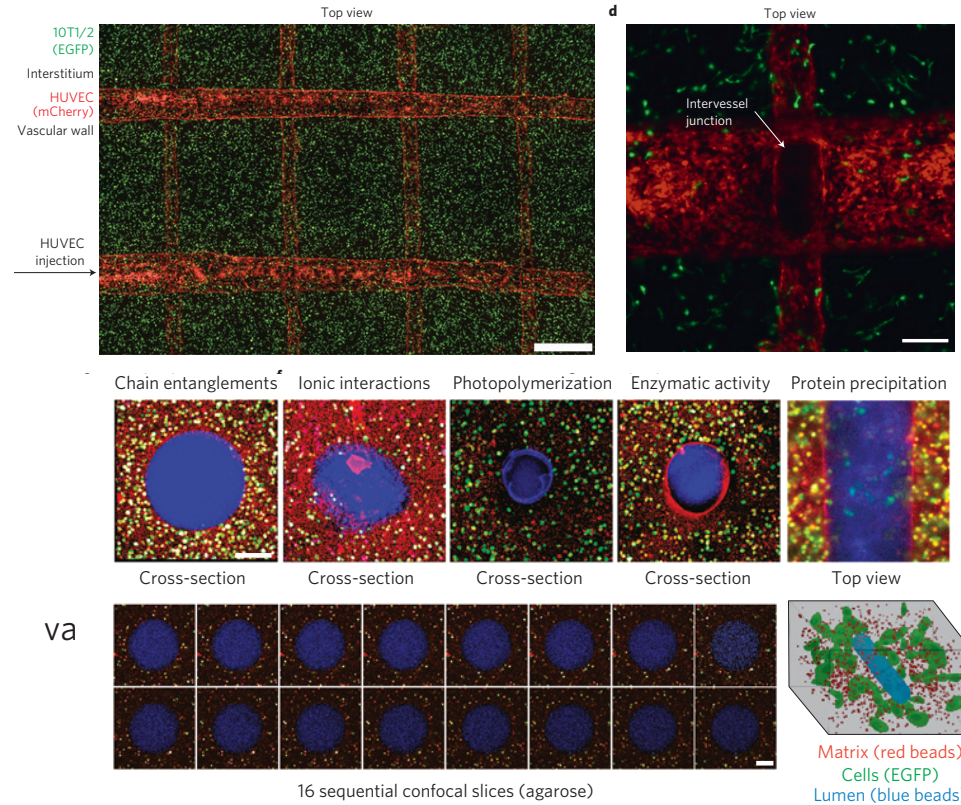
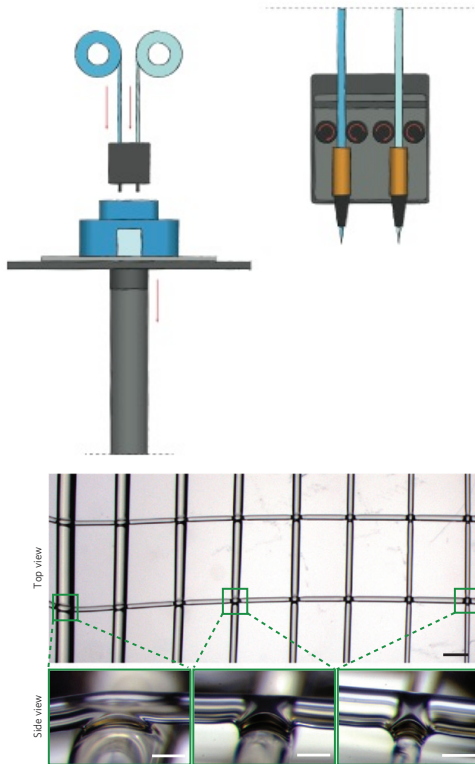

+ *3D System Multi-jet Modeling*

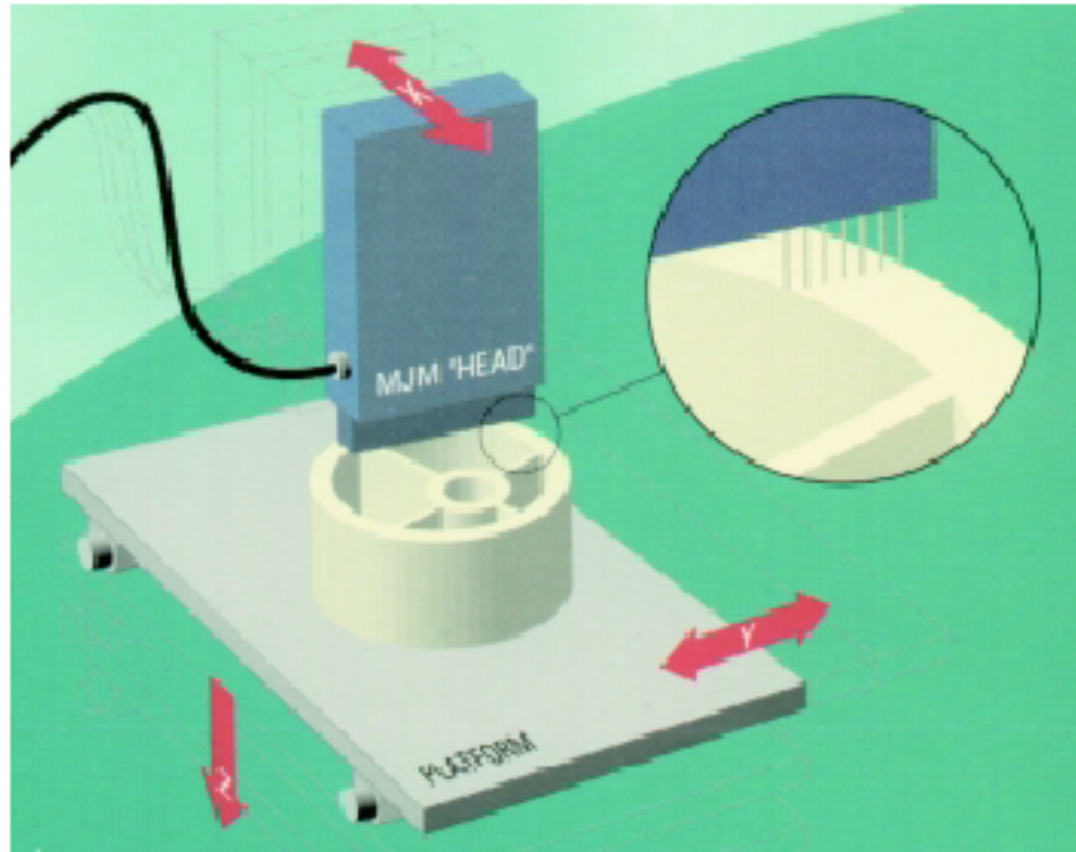

+ Shape Deposition Manufacturing

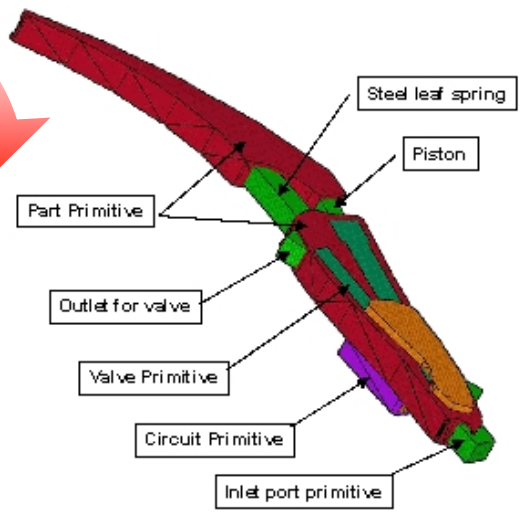
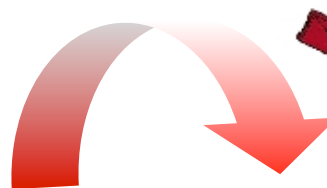
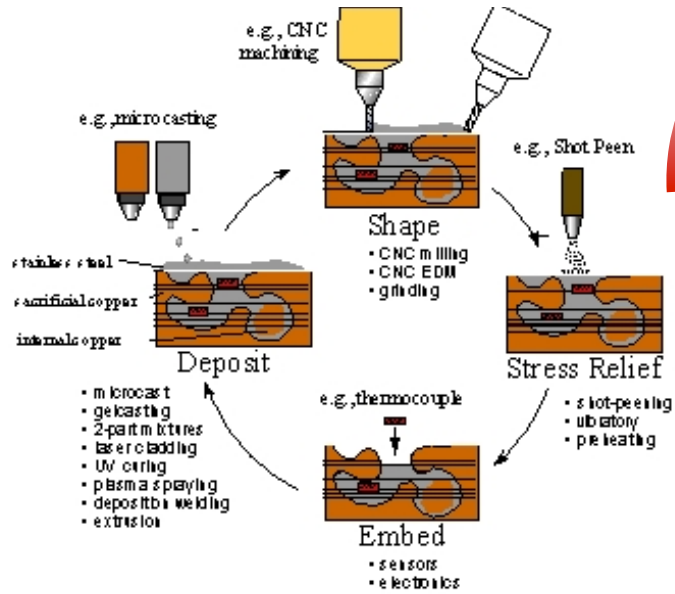

Designer composes the design from library of primitives, including embedded components

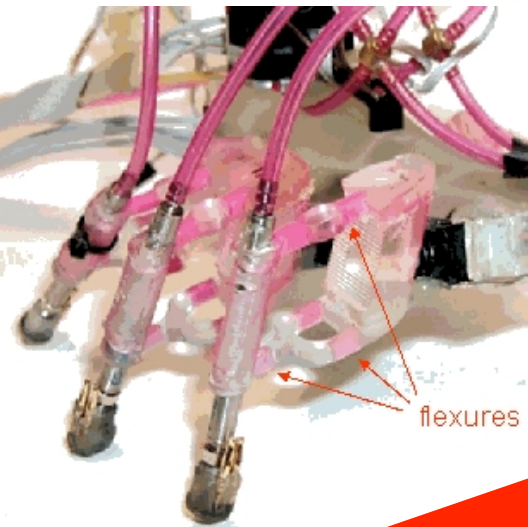

embedding sensors and actuators



Indirect Rapid Prototyping (iRP)

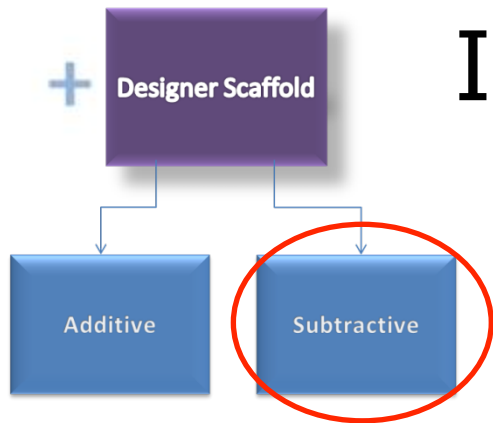

- Molds realised with RP devices (CAD/CAM)
- Casting of the desired (bio-) material
- Extraction of the final object

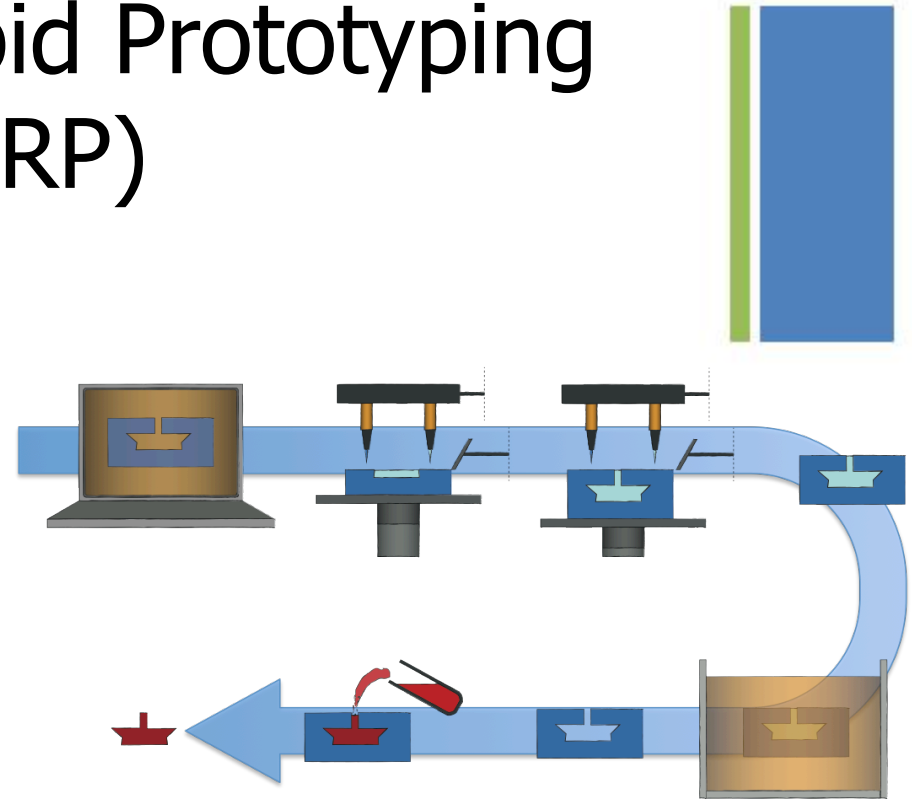

Advantages?
Limitations?

Materials?
Speed?
Price?
Fidelity?

DW Hutmacher et al., Trends in Biotechnology, 22(7): 354 – 362, 2004

