

# Micro e Nano Sistemi

---

G. Vozzi

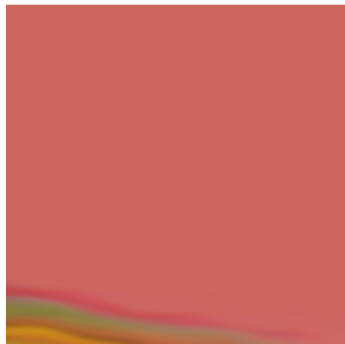

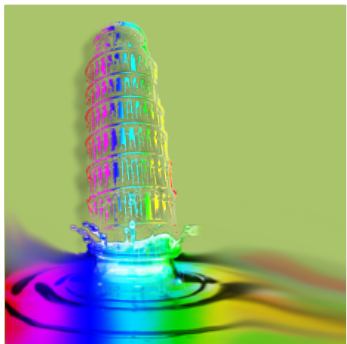
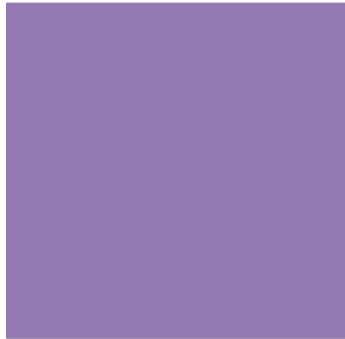

# Contatti



- Giovanni Vozzi
  - [g.vozzi@centropiaggio.unipi.it](mailto:g.vozzi@centropiaggio.unipi.it)
- Carmelo De Maria
  - [carmelo.demaria@centropiaggio.unipi.it](mailto:carmelo.demaria@centropiaggio.unipi.it)
- Gianni Orsi
  - [g.orsi@centropiaggio.unipi.it](mailto:g.orsi@centropiaggio.unipi.it)



# Siti internet di riferimento



- <http://www.centropiaggio.unipi.it/course/micro-e-nanosistemi.html>
- <http://dionisio.centropiaggio.unipi.it/gvozzi/default.aspx>
- <http://dionisio.centropiaggio.unipi.it/cdemaria/default.aspx>



# Programma preliminare del corso



- Microfabbricazione 2D
- Microfabbricazione 3D e tecnologie di prototipazione rapida
- Analisi Multifisica agli elementi finiti



# Presequisiti

- Analisi Matematica
- Fisica
- Chimica
- Scienze dei Materiali





# Modalità d'esame



- Una domanda per ogni parte del corso
- Tesina teorico-pratica su un argomento del corso:
  - Analisi dello stato di sforzo indotto da un raffreddamento non omogeneo
  - Sintesi di un controllore di temperatura
  - Analisi fluidodinamica di estrusori
  - ...



# Ricevimento

- Prenotazione tramite e-mail (Vozzi, De Maria o Orsi) a seconda del particolare argomento da trattare
- Il ricevimento è sospeso durante la settimana d'esame





# Materiale didattico

- Slide ed appunti forniti dal docente
- Libri di riferimento:
  - Madou, Fundamentals of Microfabrication, CRC Press
  - Gebhardt, Rapid Prototyping, Hanser Verlag





# **MICROFABBRICAZIONE 2D**

+

# Litografia

- Dalle proprietà del silicio alla fabbricazione di circuiti integrati

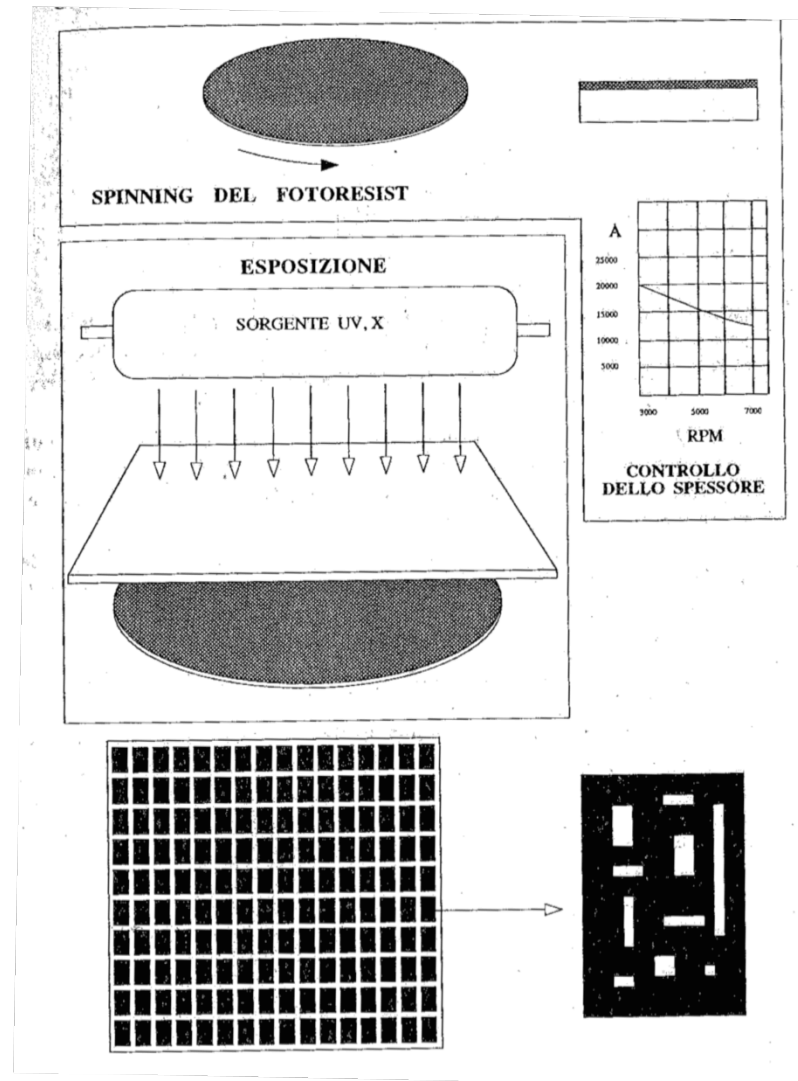



# Litografia

- Dalle proprietà del silicio alla fabbricazione di circuiti integrati

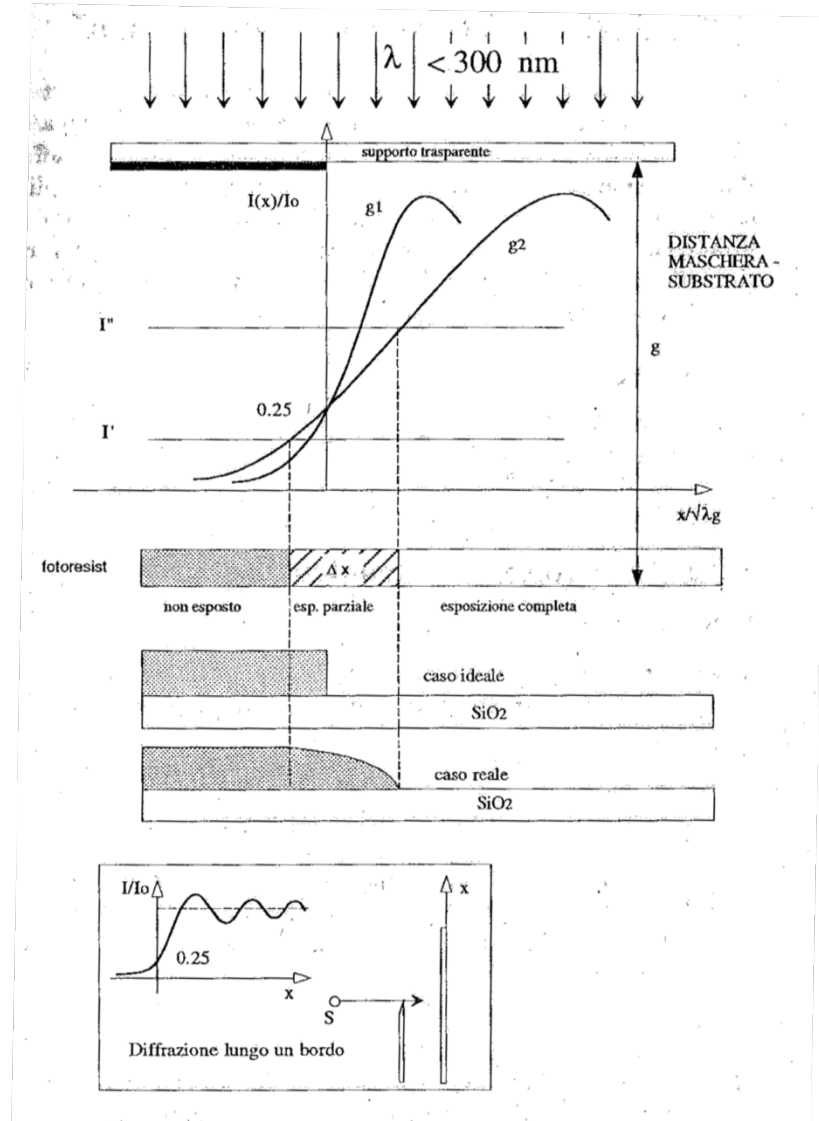



# Soft-litografia

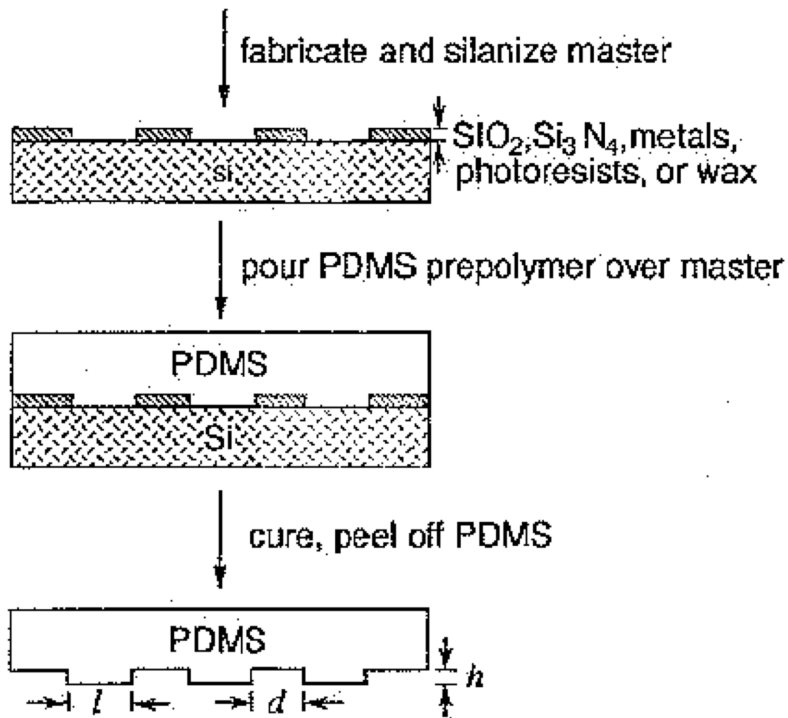

# **MICROFABBRICAZIONE 3D**

+



3D  
fabrication

Additive

Subtractive





# 3D printing



- 3D printing (or Additive Manufacturing) is a process of making a three-dimensional solid object of virtually any shape from a digital model.
- 3D printing is achieved using an additive process, where successive layers of material

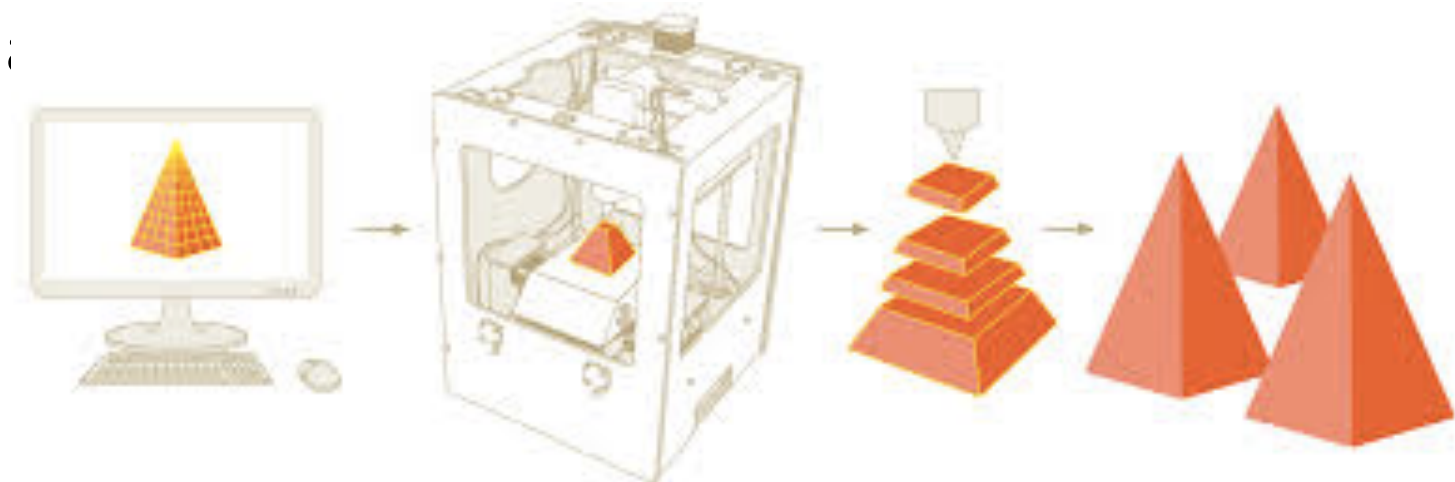



# Additive manufacturing world

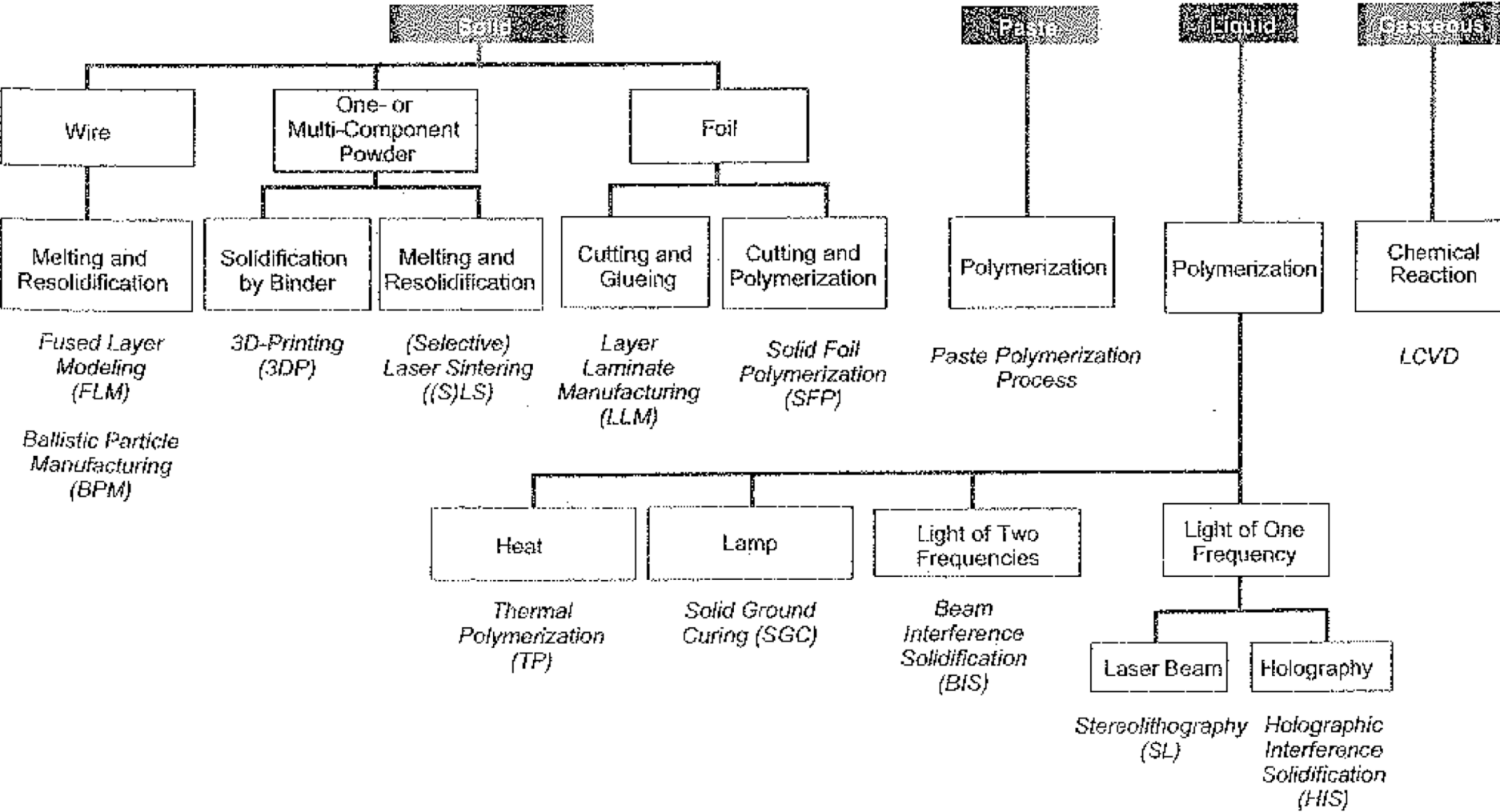



+

# Available technologies



- Solidification of liquid materials
  - Photo-polymerization process

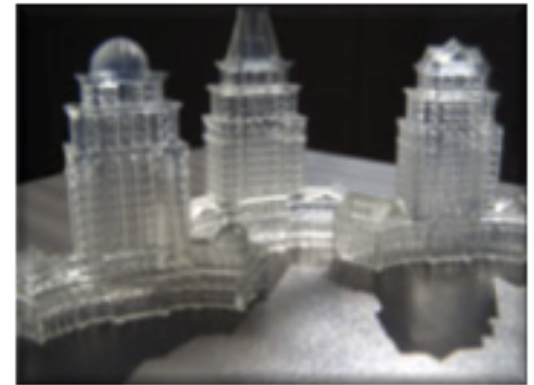
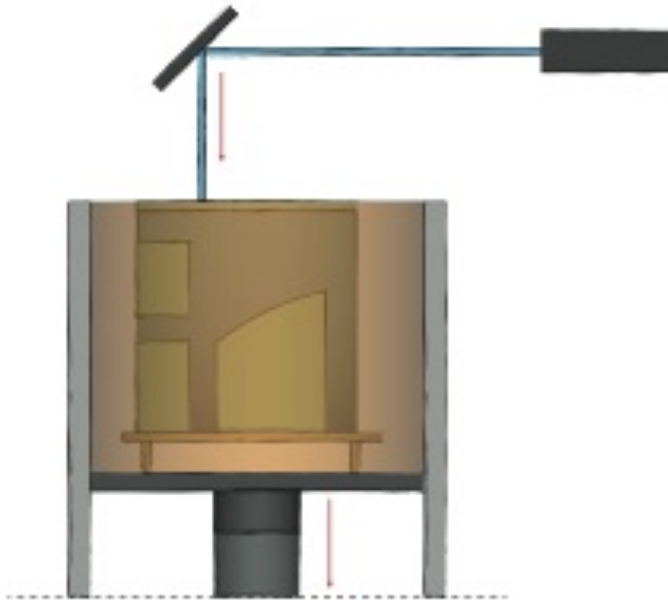



# Available technologies



- Generation from the solid phase:
  - incipiently or completely melted solid materials, powder, or powder mixtures:
    - Extrusion (FDM),
    - Ballistic and
    - Sintering processes

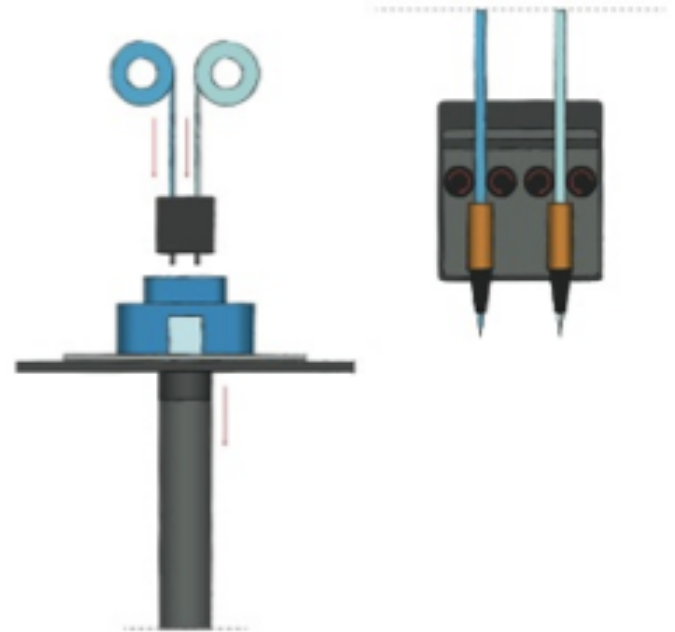



# Available technologies



- Generation from the solid phase:
  - incipiently or completely melted solid materials, powder, or powder mixtures:
    - Extrusion (FDM),
    - Ballistic and
    - Sintering processes



+

# Available technologies



- Generation from the solid phase:
  - Conglutination of granules or powders by additional binders
    - 3D inkjet printer

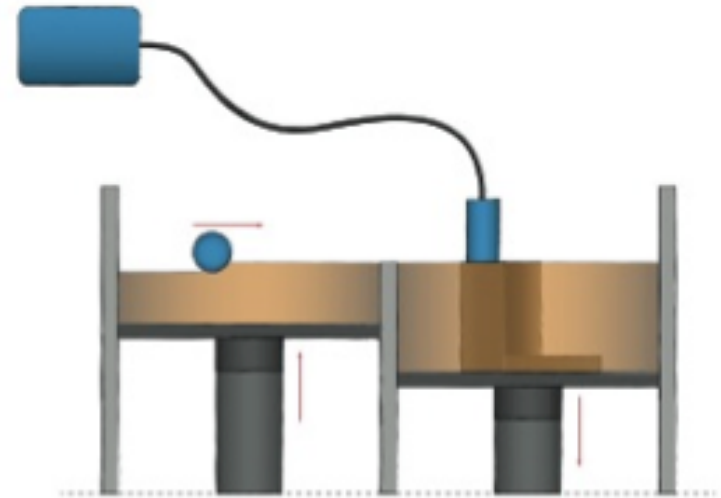

+

# 3D printer as a whole

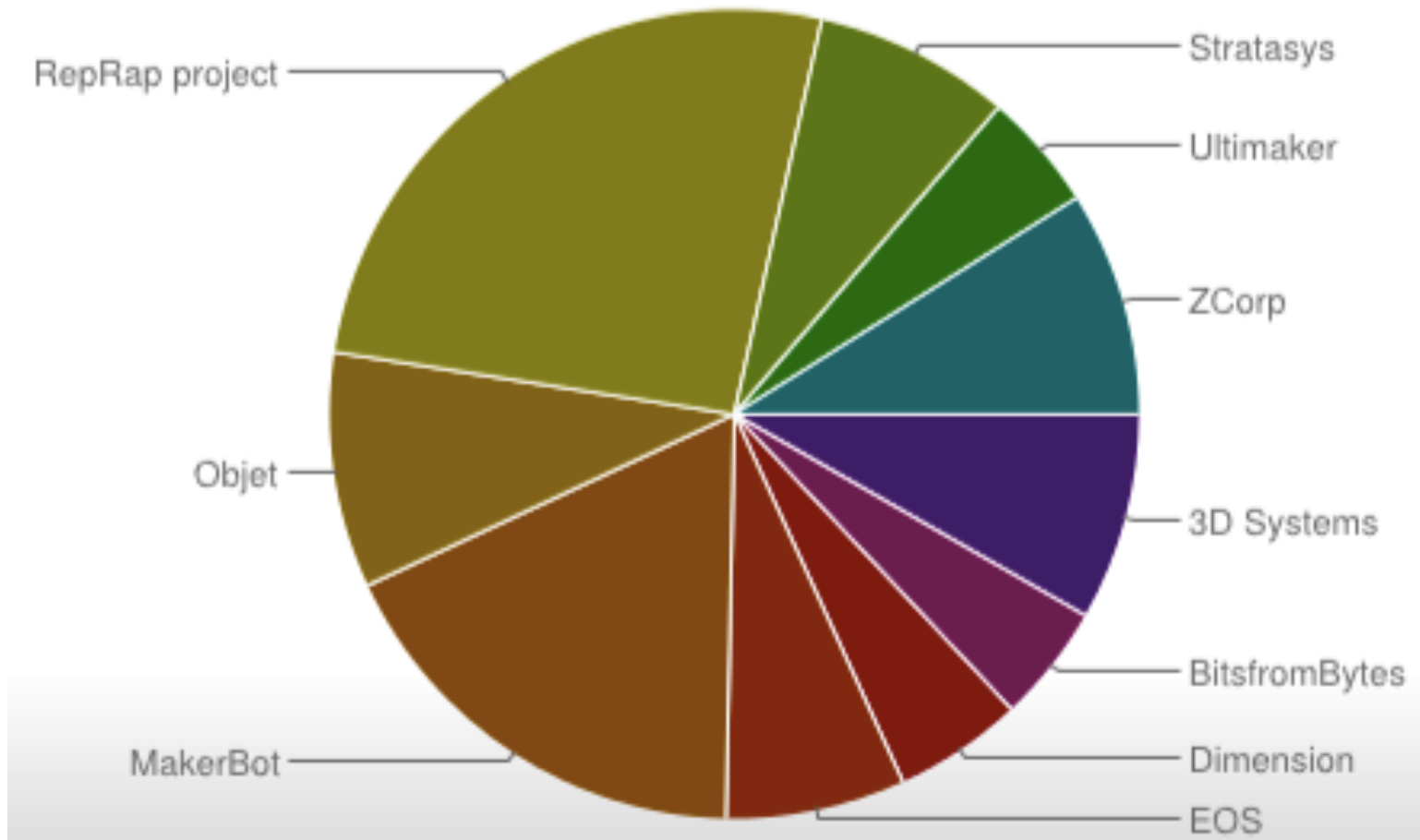

+

# The RepRap Project

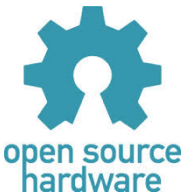
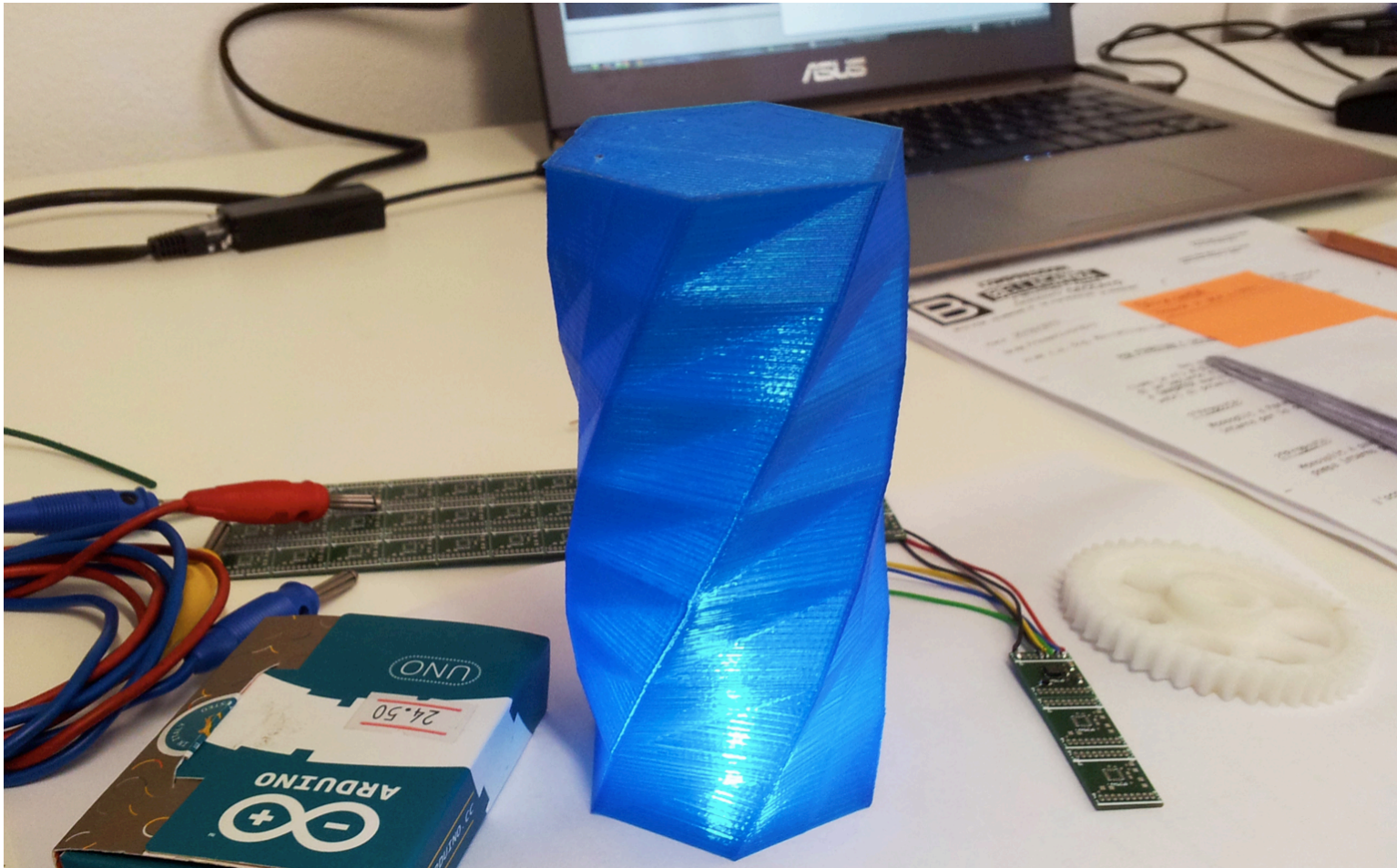

+

# Other fabrication technologies

- Subtractive technologies

- Laser cutter
- CNC milling machines

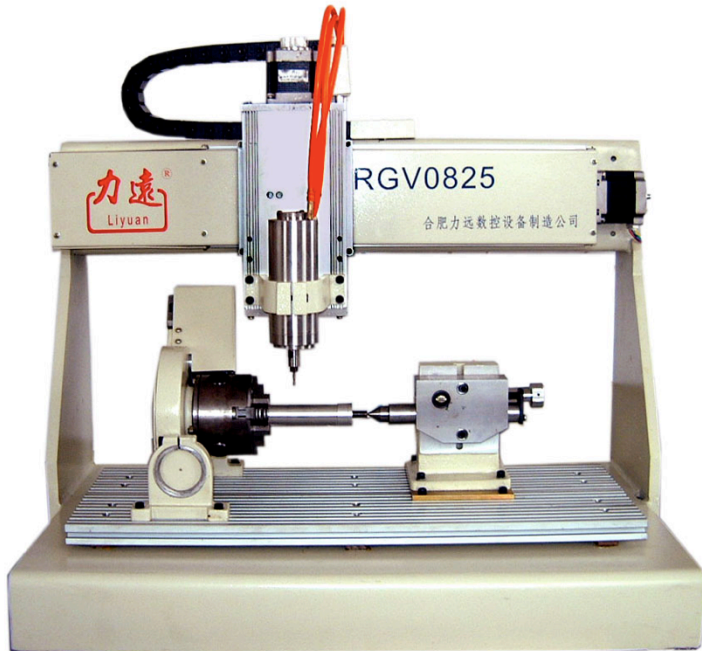
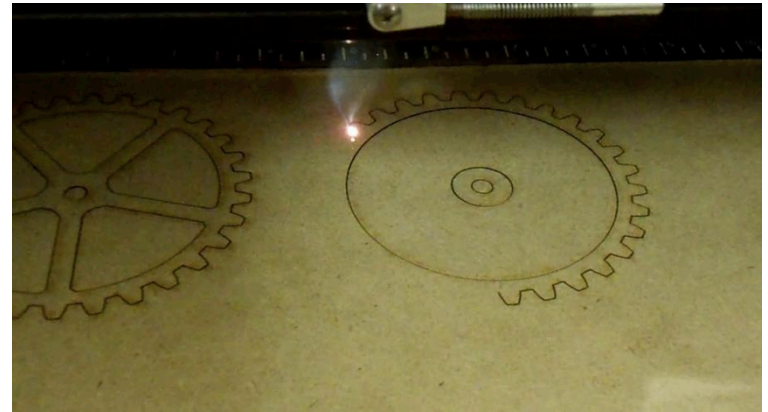

# **ANALISI MULTIFISICA AGLI ELEMENTI FINITI**





# Analisi agli elementi finiti



- Metodo per la risoluzione **numerica** di una equazione differenziale, sia essa alle derivate totali o parziali
- Più precisamente si tratta di un metodo per approssimare una equazione differenziale con un sistema di equazioni algebriche



# Analisi agli elementi finiti

- Elementi
- Nodi
- Funzioni Forma
- Gradi di libertà

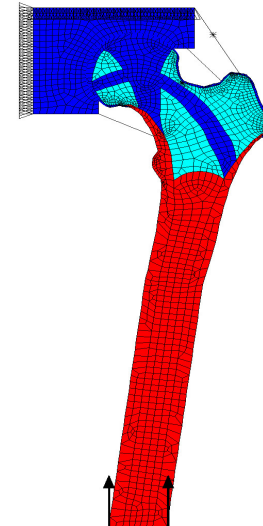
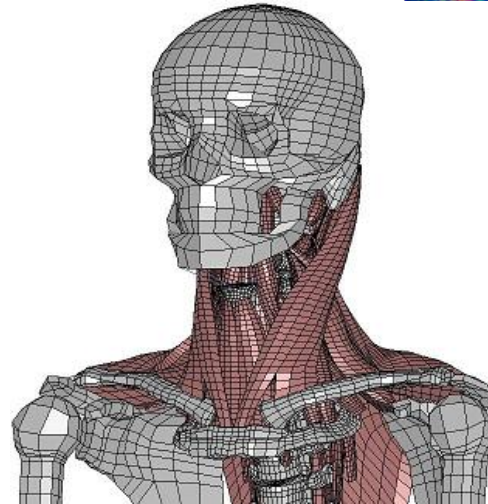
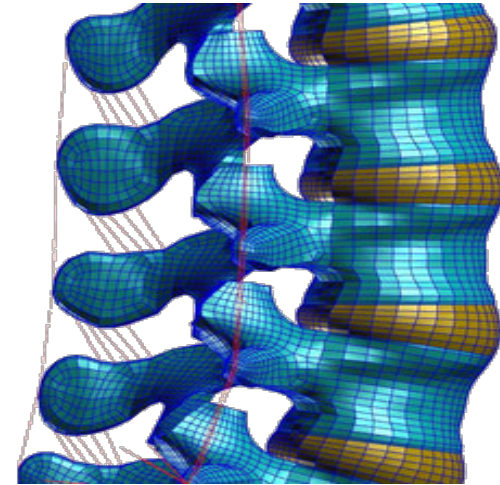



# Comsol Multiphysics

